



AUTOGUIDE EQUIPMENT



POLE JACK AND FOOT PEDAL UNIT

MANUAL SPARE PARTS

Autoguide Equipment Ltd
Stockley Road,
Heddington, Calne,
Wiltshire, UK,
SN11 0PS
+44(0)1380 850885
www.autoguide.co.uk



Published: 18 July 2024
ID: M058 2.0

ORIGINAL INSTRUCTIONS

These instructions give safety and operations information regarding the use of the Pole Jack and Foot Pedal Unit supplied by Autoguide Equipment. They contain the relevant information for products:

Product Code	Description	Max Pressure (Bar)	Max Flow (L/min)
55486	Pole Jack Kit	130	30
55485	Pole Jack Lorry Kit	130	30
49235	Foot Pedal	200	30

To ensure optimum results when operating this equipment it is very important to read this manual carefully, the information will prepare you to do a better, safer job.

Before operating the machine you should familiarise yourself with the instructions in this manual. Incorrect use can lead to damage which is not covered by the Warranty Conditions. This may create a dangerous situation or lead to unsatisfactory results.

These operating instructions **MUST** always be made available to the person or persons operating this equipment.

To assist in the ordering of spares, or other communications with our company, the serial number of the relevant equipment supplied, has been recorded below for your information.

Model No:-

Serial No:-

Date of Delivery:-



Read and understand all instructions. Failure to follow all instructions listed below may result in serious injury.



Do not allow persons to operate this product until they have read this manual and developed a thorough understanding of how the product works.



The warnings, cautions and instructions in this manual cannot cover all possible conditions or situations that could occur. It must be understood by the operator that common sense and caution are factors which cannot be built into this product, but must be supplied by the operator.

CONTENTS

Information	5
Warnings	5
Description	6
Important Information regarding Design, Use & Inspection	6
Dataplate Information	7
Declaration of Conformity	8
Machine Safety.....	9
Machine Familiarisation	10
Pole Jack Kit.....	10
Foot Pedal	11
Technical Data	12
Dimensions – Pole Jack Kit	12
Weight – Pole Jack Kit.....	12
Dimensions – Foot Pedal.....	13
Weight – Foot Pedal	13
Machine Operation	14
General Precautions	14
Safety Rules	14
Safety Features	14
Personal Protection.....	14
How Not to Use the Machine	15
Unauthorised Modification.....	15
Noise and Vibration Reduction.....	15
Operator Position.....	15
Preparation.....	15
Site Restrictions.....	16
Overhead Infrastructure	16
Set Up with Pole Erection Unit Lorry.....	17
Machine Requirements	17
Hydraulic Attachment.....	17
Set Up with Powerpack with Foot Pedal	19
Machine Requirements	19
Hydraulic Attachment.....	19
Pole Extraction with Pole Erection Unit Lorry	23
Pole Extraction with Powerpack and Foot Pedal.....	26

Service Information.....	31
Service Schedule.....	31
Daily Check Sheet	32
Bolt Tightening.....	33
Hydraulic Oil	33
Troubleshooting.....	34
End of Life	36
Warranty.....	37
Spare Parts	38
55486 - Pole Jack Kit.....	38
55482 - Pole Jack Ram	39
55485 –Pole Jack Lorry Kit	40
49235 – Foot Pedal Assembly	41
49236 – Foot Pedal Hydraulics	42
49226 – Foot Pedal Hoses	43
50788 – Feed Hoses	44

INFORMATION

Your Pole Jack and Foot Pedal has been individually built with great emphasis on quality, strength and simplicity of design and with routine care will give many years of trouble free operation.

The following instructions have been written to cover the machine. Care should be taken to ensure that you are referring to the correct section of your machine before carrying out any adjustments, or when ordering spare parts.

Like all mechanical products, regular cleaning, lubrication and maintenance will ensure a longer trouble free life. These instructions make no attempt to go beyond routine maintenance, and it is strongly advised that you contact your dealer should any major repairs become necessary.

Use only genuine service parts; non genuine parts may not meet standards required for safe and satisfactory operation.



Observe all safety information in the manual and on decals fitted to the machine and power unit.

Warnings

- Improper operation and maintenance of this equipment can be hazardous and could result in serious injury or death.
- Do not modify the equipment in any way. Unauthorized modifications may impair the function and/or safety and could affect the life of the equipment.
- Operators and maintenance personnel should read this manual thoroughly before beginning operation and maintenance.
- Always keep this manual with the equipment and be sure to read and understand it thoroughly before performing operation and maintenance.
- Some actions involved in operation and maintenance of the machine can cause serious accident if they are not done in the manner described in this manual.
- If this manual has been lost or has become dirty and cannot be read, request a replacement manual from Autoguide Equipment Ltd.
- If you lend this equipment to another person, always have that person read the operation manual and make sure that they understand the content of the manual before starting operation. Be particularly careful to ensure that they follow the safety regulations when operating.

Description

The pole jack is designed to remove telegraph poles from the ground. It uses a chain to grip the pole and hydraulic power to pull the pole out of the ground. It must be used in conjunction with a crane or similar to support the pole to prevent the pole falling over once loosened from the ground.

A foot pedal is available to control the Pole Jack where required. It consists of a hydraulic valve and pedal assembly to control the ram, plus 2 long hydraulic hoses so the operator can stand a safe distance from the pole being removed.

The Pole Jack is required to be attached to a hydraulic power pack source which must not produce in excess of **200 Bar** and **30 L/min** or damage may occur to the pole jack.

Important Information regarding Design, Use & Inspection

Autoguide Equipment manufacture the utility Pole Jack to work in conjunction with a lorry loader for safe and controlled pole removal.

The jack is used to apply a vertical load at the base of the pole to break friction with the ground. During the original testing the brief was defined to include, reliability and lightweight. Our unique design using the hollow ram rod and specific chain achieved these objectives and has been regularly and actively improved over the last 30 years.

The action of the jack applies a vertical load direct to the pole once the lorry loader is in position to lift and extract the pole.

The chains have been specified for use with the Autoguide Pole Jack only; this allows the application to use a unique design of chain to match the rating of the product.

The onward requirements of the customer and 3rd party is to regularly check the condition of the complete assembly, ram, base plate and chain, to ensure the condition is good and without defect. Please refer back to Autoguide should there be any questions. We would advise to follow best practice on this and document the checks for your records.



The chain is specific to the Pole Jack so does not follow the LOLER guidelines on size and SWL. This has been designed to ensure the practical usability of the equipment from a manual handling level. The equivalent 'lifting' chain to the same specification would be 20mm links, these would not allow for the 'bite' on a 12-18" timber pole and would also increase the weight of the assembly by 20%. As the application is for jacking poles only the requirements to meet Lifting regulations do not apply. This is allowable by the correct use of the equipment with the lorry loader lifting the pole and the Pole Jack assisting in its approved application.

As with other chains and slings the Pole Jack chain should retain the appropriate label showing the assembly serial number and chain number – this tag also has the instruction of Pole Jack use only along with UKCA/CE marking.

There has been supplementary information sent out regarding the correct used of the Pole Jack and chain positing in the clutch on the ram in 2020. Along with a new system of identifying the serial number marking all three items – base plate holds the serial number plate and information, chain retains the tag as describes and the ram is stamped on the chain clutch with the 4 digit code.

Dataplate Information

The machine is fitted with a data plate with the machine specifications and information.

		AUTOGUIDE EQUIPMENT			
		Stockley Road, Heddington, Wiltshire, SN11 0PS England Tel: +44 (0) 1380 850885 email: sales@autoguide.co.uk website: www.autoguide.co.uk		S/No.	<input type="text"/>
				MODEL	<input type="text"/>
				YEAR	<input type="text"/>
RATED CAPACITY	<input type="text"/>	kNm KG		MAX PRESSURE	<input type="text"/>
WEIGHT	<input type="text"/>	KG		MAX FLOW	<input type="text"/>
READ & UNDERSTAND OPERATION INSTRUCTIONS BEFORE USE					

The information for Pole Jack Kit is:

Model	55486
Rated Capacity	10,800 <i>KG</i>
Weight	50 <i>KG</i>
Max Pressure	130 <i>Bar</i>
Max Flow	30 <i>L / Min</i>

The information for Pole Jack Lorry Kit is:

Model	55485
Rated Capacity	10,800 <i>KG</i>
Weight	50 <i>KG</i>
Max Pressure	130 <i>Bar</i>
Max Flow	30 <i>L / Min</i>

The information for Foot Pedal is:

Model	49235
Rated Capacity	
Weight	22 <i>KG</i>
Max Pressure	200 <i>Bar</i>
Max Flow	30 <i>L / Min</i>

DECLARATION OF CONFORMITY



Declaration of Conformity (UKCA Marking)



<p>Name & Address of Manufacturer:</p> <p><i>Autoguide Equipment Ltd, Stockley Road, Heddington, CALNE, Wiltshire, SN11 0PS, UNITED KINGDOM</i></p>	<p>Name & Address of person to compile the Technical File:</p> <p><i>Mr Adam Sandey, Lead Design Engineer, Autoguide Equipment Ltd, Stockley Road, Heddington, CALNE, Wiltshire, SN11 0PS, UNITED KINGDOM</i></p>
<p>Name & Address of Authorised Representative if one has been mandated by the manufacturer:</p> <p><i>N/A</i></p>	
<p>Name, Address, and identification number of the Approved Body, where applicable:</p> <p><i>N/A</i></p>	
<p>Description of the Equipment:</p> <p><i>55486 – Pole Jack Assembly</i></p> <p><i>55485 – Pole Jack Crane Assembly</i></p> <p><i>49235 – Foot Pedal Control Unit</i></p>	
<p>The transposed harmonised standards (Designated Standards BS prefix) used:</p> <p><i>EN ISO 12100:2010 – Safety of machinery - Human physical performance - Part 2. Manual Handling of machinery and component parts of machinery</i></p> <p><i>BS EN ISO 4413:2010 – Hydraulic fluid power - General rules and safety requirements for systems and their components</i></p> <p><i>BS EN 818-4 – Short Link chain for lifting purposes – Safety – Part 4: Chain Slings – Grade 8</i></p>	
<p>The British National standards and any technical specifications used (Specify):</p> <p><i>N/A</i></p>	
<p>Place of Declaration: <i>Calne, United Kingdom</i></p> <p>Date of Declaration:</p>	

I declare that the above equipment meets the Essential Health and Safety requirements of the Supply of Machinery (Safety) Regulations 2008 and 2006/42/EC Machinery Directive

<p>Name: <i>Mr Robert Robinson</i></p>	
<p>Position: <i>Managing Director</i></p>	

MACHINE SAFETY

The machine is fitted with numerous safety stickers highlighting the potential dangers. Please take note of these warnings as they are there to protect from dangers.

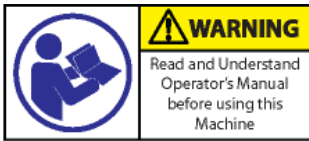

Operator Manual Must be read before operation.



Toe Protection Footwear Mandatory



Hard Hat Mandatory



High Visibility Clothing Mandatory



Gloves Mandatory



Manual Handling required. Always lift properly.



Crush Hazard. Keep Hands Clear Of Moving Parts.



Crush Hazard. Keep Feet Clear Of Moving Parts.

MACHINE FAMILIARISATION

Pole Jack Kit

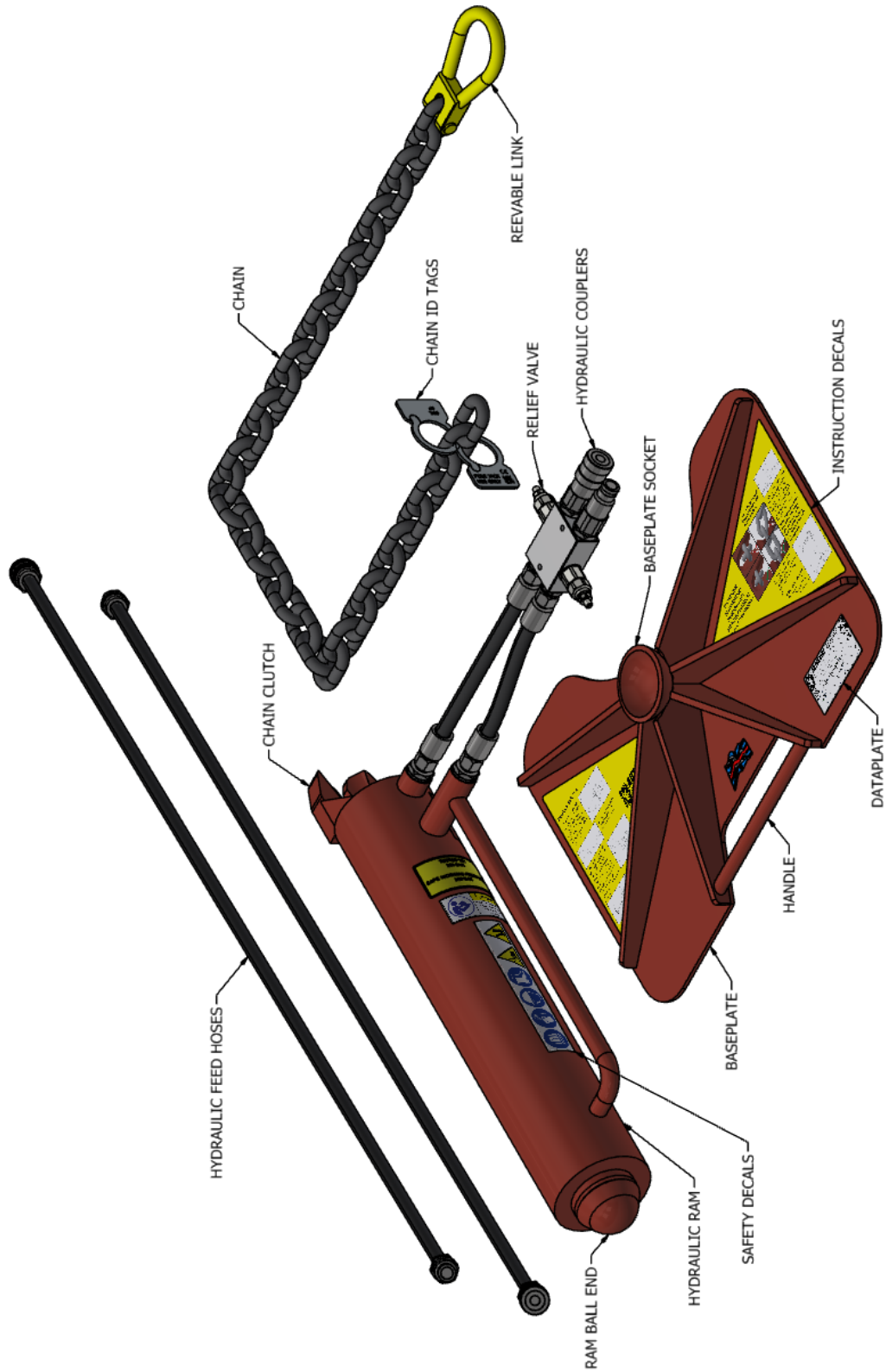

Foot Pedal

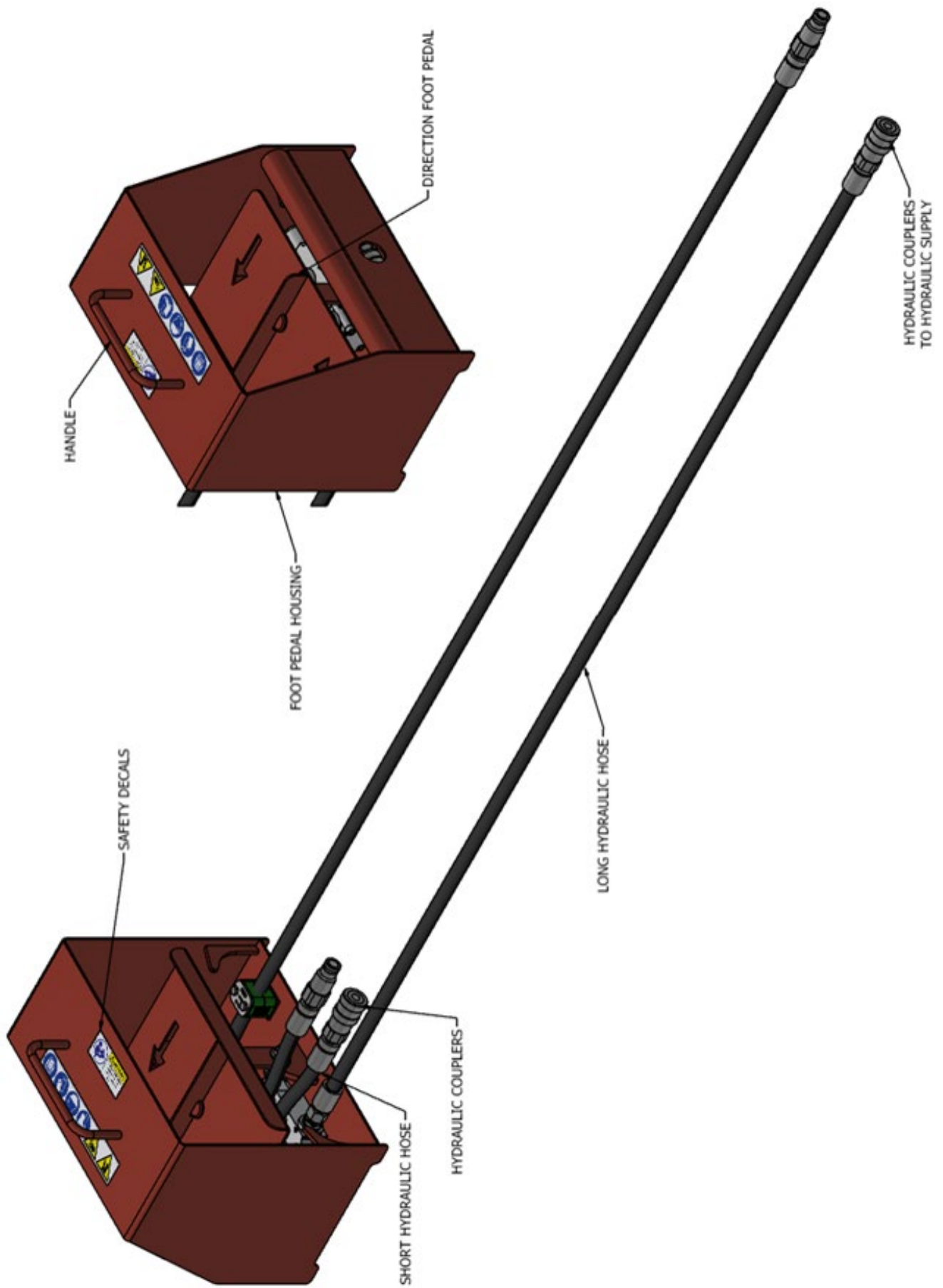

TECHNICAL DATA

Dimensions – Pole Jack Kit

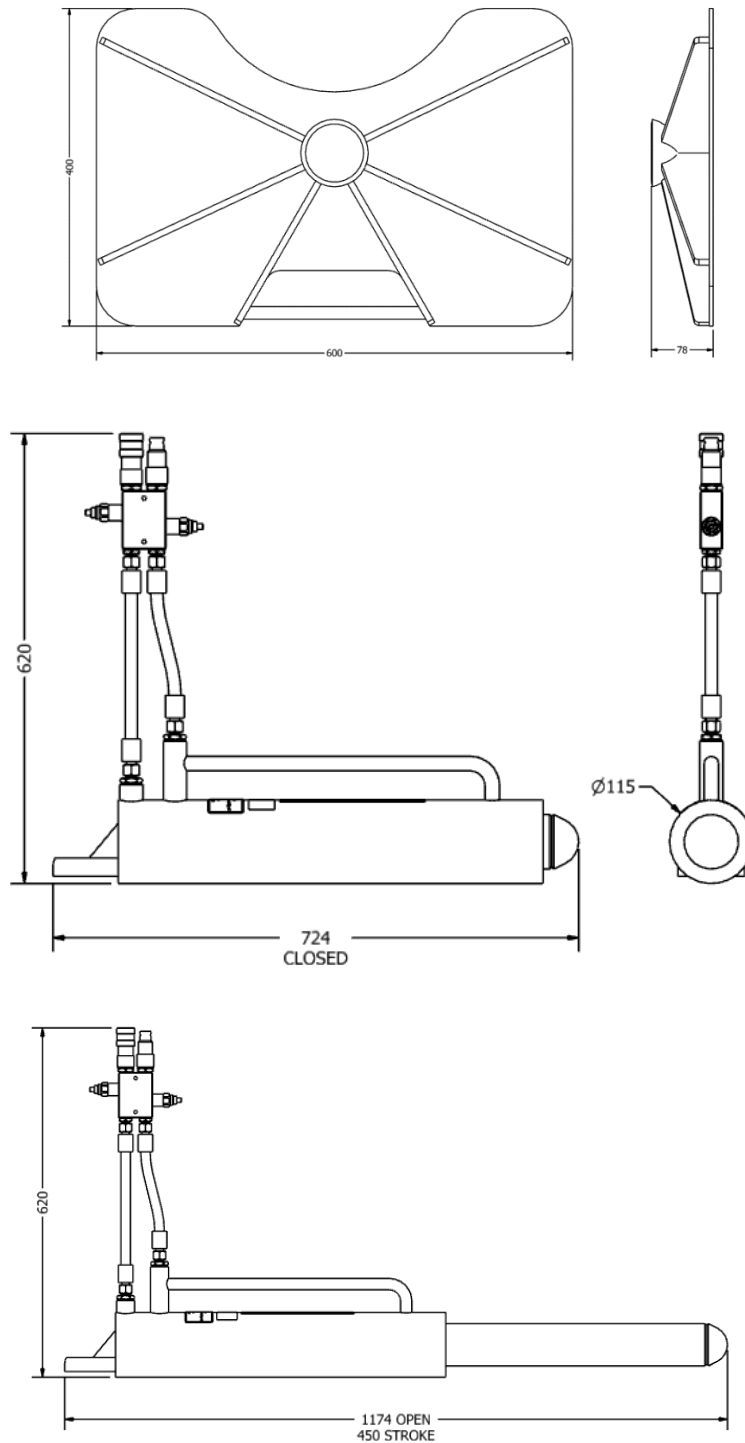

Weight – Pole Jack Kit

The weight of the Base Plate is 14 Kg.

The weight of the Ram is 30 Kg.

The weight of the Chain is 7 Kg.

Dimensions – Foot Pedal

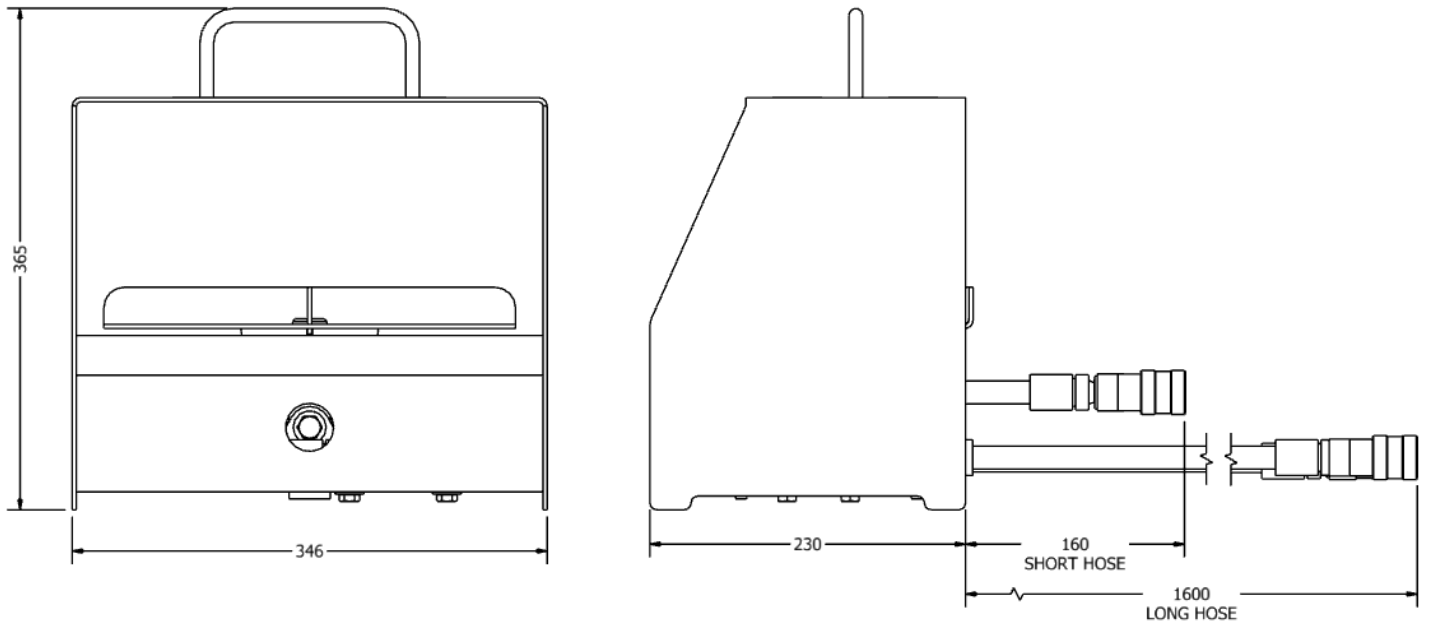

Weight – Foot Pedal

The weight of the Foot Pedal is 22 Kg.

MACHINE OPERATION

General Precautions



Failure to follow these general safety precautions may lead to a serious accident.



The safe operation of this machine is the responsibility of the operator, who should be familiar with the principles of pile installation, the power unit and all safety practices before starting operations.

Safety Rules

- Only trained and qualified personnel or personnel authorised by the company (or superior) can operate and maintain the machine.
- Read and understand this operator's manual prior to operating the machine and keep it in a convenient place for future reference.
- Follow all safety rules, prohibitions, precautions, procedures and instructions when operating or performing maintenance on the machine and pay careful attention to safety.
- Operating the machine when you are not in good physical condition reduces the power of judgment needed to avoid danger and leads to accidents.
- People in the following conditions should not operate the machine.
 - People who cannot operate normally because they are ill, or suffering from the effects of medication.
 - People who have been drinking
 - Pregnant women
- All oil spills, however small must be cleaned up straight away to prevent becoming a slip hazard.
- Ensure daily checks are completed prior to machine use.

Safety Features

- Be sure that all guards and covers are in their proper position. Have guards and covers repaired if damaged.
- Improper use of safety features could result in serious bodily injury or death.
- **Do not** adjust the relief valve.

Personal Protection

- Always wear properly fitting clothes which allow ease of movements.
- Avoid loose clothing, towels, jewellery and loose long hair. They can catch on controls or in moving parts and cause injury or death.
- Also, do not wear oily clothes; they can easily catch fire.
- Wear a hard hat, eye protection, non-slip safety shoes and gloves when operating or performing maintenance on the machine

- It is advised that no untrained persons be allowed on the site whilst the machine is in operation.

How Not to Use the Machine

- The machine should only be used for its intended purposes.
- The Pole Jack, Base Plate and Chain must be used and kept as a kit. They all share a Serial Number and must be used in conjunction with each other.
- Do not use more than 30 Litre/min of oil flow. Autoguide can supply suitable valves if it is intended to operate the unit from power sources that exceed the maximum recommended pressure and flow limits.

Unauthorised Modification

- Any modifications made without authorisation from Autoguide Equipment can adversely affect the performance of the machine and they may also create hazards.
- Before making a modification, consult Autoguide Equipment. Autoguide Equipment will not be responsible for any injury or damage caused by any unauthorised modification.

Noise and Vibration Reduction

The pole jack produces less than 75 dB and is intended to be operated from a distance, thus exposing the operator to minimal vibration.

Operator Position

- The operator should be positioned so that they have an un-interrupted view of the equipment and pole at all times.
- Any additional trained banksman must stay a minimum of 10m away from the moving equipment and pole and be wearing the appropriate PPE at all times.

Preparation

Before using the Pole Jack, all daily checks should be completed as detailed in

Daily on page 32.

Site Restrictions

Prior to use of the Pole Jack for pole removal, it is recommended to cordon off the immediate vicinity to a minimum of 10m from the location of the pole and vehicle. This area should be clearly marked to prevent unauthorised or untrained personal from entering the work area.

Overhead Infrastructure

When working at heights with Pole Erection Vehicles, care should be taken to identify all the overhead lines and or infrastructure, and plan lifts according to operational standards. Further advice regarding working near overhead lines is available from the HES website and details the precautions that need to be taken.

Set Up with Pole Erection Unit Lorry

Machine Requirements

The hydraulic requirements for the pole jack are 30 Litre per minute and up to 200 Bar.

Hydraulic Attachment



1. Clean the hydraulic quick couplers on both the pole jack ram and the end of the hydraulic feed hoses from the PEU lorry.

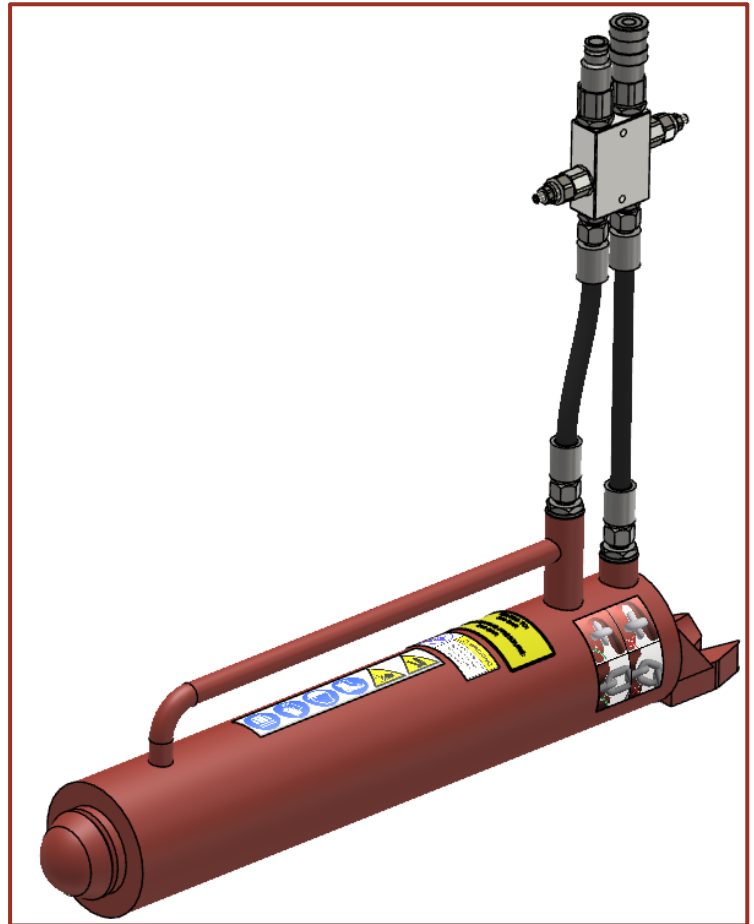

Not cleaning the quick couplers may enable dirt to enter the system and damage the hydraulic motor and valve, reducing performance and efficiency.

2. Connect the hoses from the PEU lorry to the pole jack ram, ensuring that the couplers spring shut and twist to lock.

The ram is fitted with ½" Flat Face Quick Couplers as standard.

The female coupler on the ram is for extending the ram.

The male coupler on the ram is for retracting the ram.



- Using the hydraulic controls on the PEU lorry cycle the ram through its full extents 10 time to remove any air from the system.

Take note to observe in which direction the control lever is operated to extend the ram for future operation.

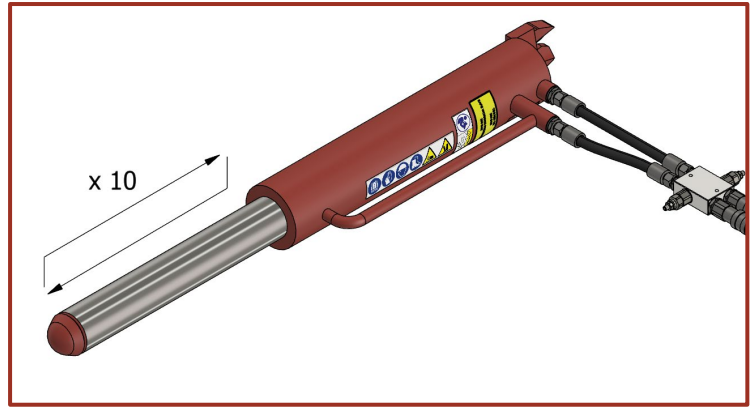

Set Up with Powerpack with Foot Pedal

Machine Requirements

The hydraulic requirements for the pole jack are 30 Litre per minute and up to 200 Bar.

Hydraulic Attachment



4. Clean the hydraulic quick couplers on the pole jack ram, the foot pedal and the hydraulic extension hoses.

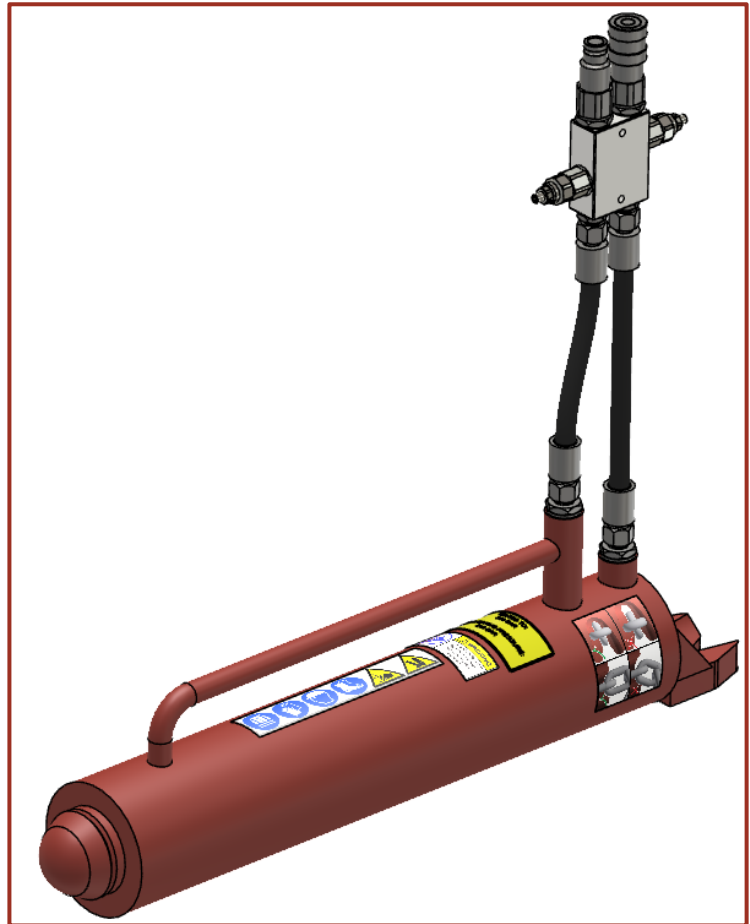

Not cleaning the quick couplers may enable dirt to enter the system and damage the hydraulic motor and valve, reducing performance and efficiency.

5. Connect the feed hoses to the pole jack ram, ensuring that the couplers spring shut and twist to lock.

The ram is fitted with ½" Flat Face Quick Couplers as standard.

The female coupler on the ram is for extending the ram.

The male coupler on the ram is for retracting the ram.

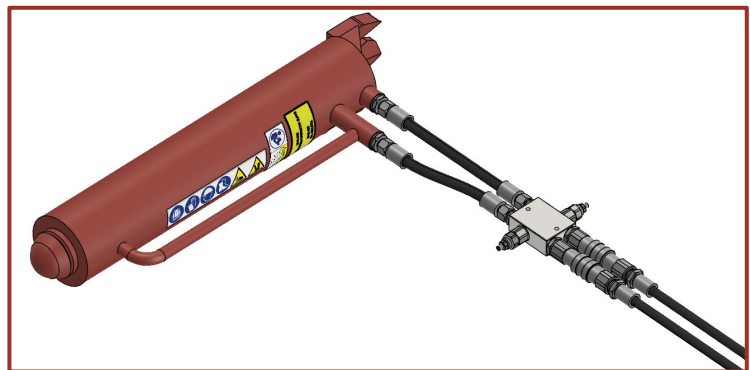

6. Place the foot pedal on stable level ground, outside the exclusion zone and connect the feed hoses to the short hoses from the foot pedal.

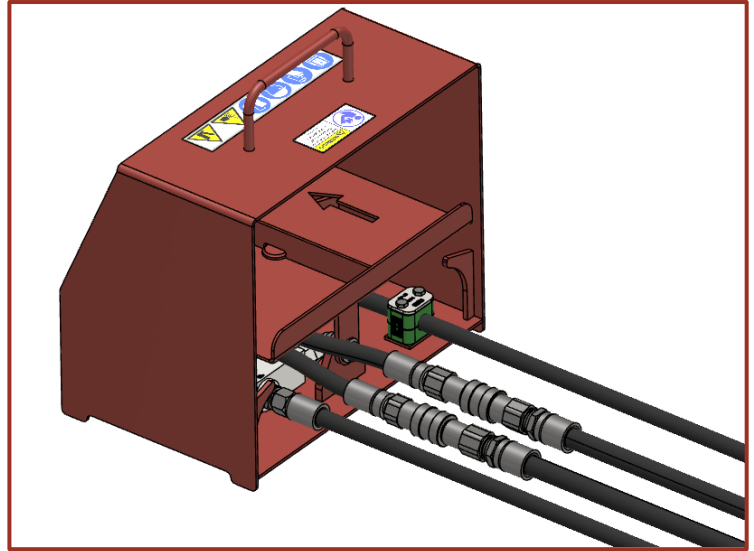

The steps below are for use with an Autoguide powerpack, if the pole jack and foot pedal is being used with another type of power pack refer to its operating manual for connection and controls information.

7. With the powerpack switched off, ensure the system is depressurised by moving the On/Off lever to the *On* position

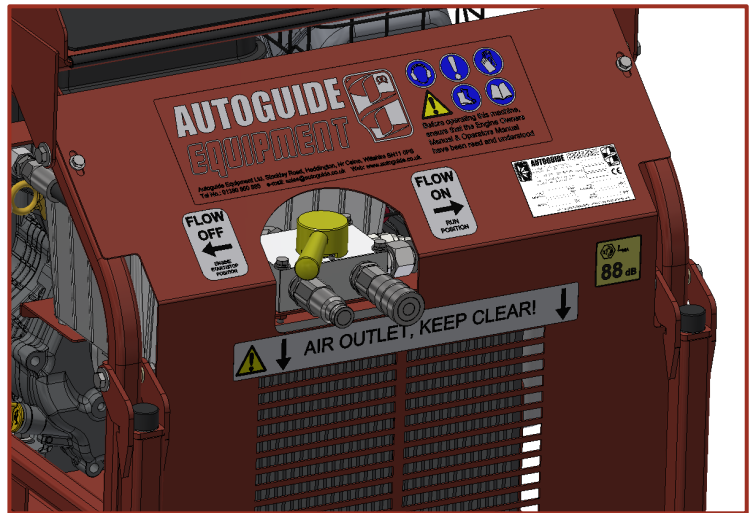

8. Clean the quick couplers on both the powerpack and hydraulic feed hoses.

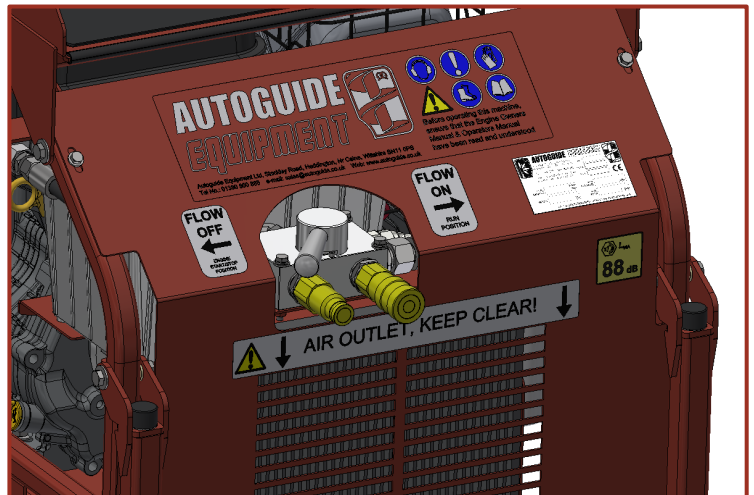

9. First connect the return line to the powerpack, followed by the pressure line. Ensure the quick couplers seal and twist to secure.

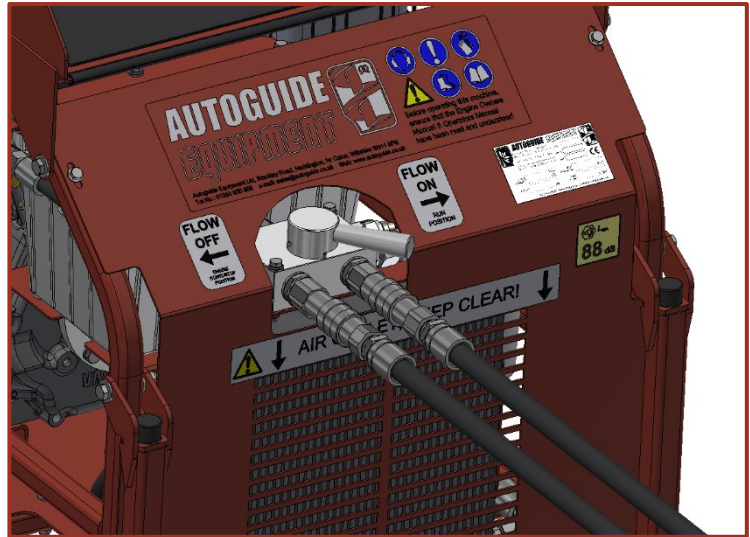

10. The set up should look like:

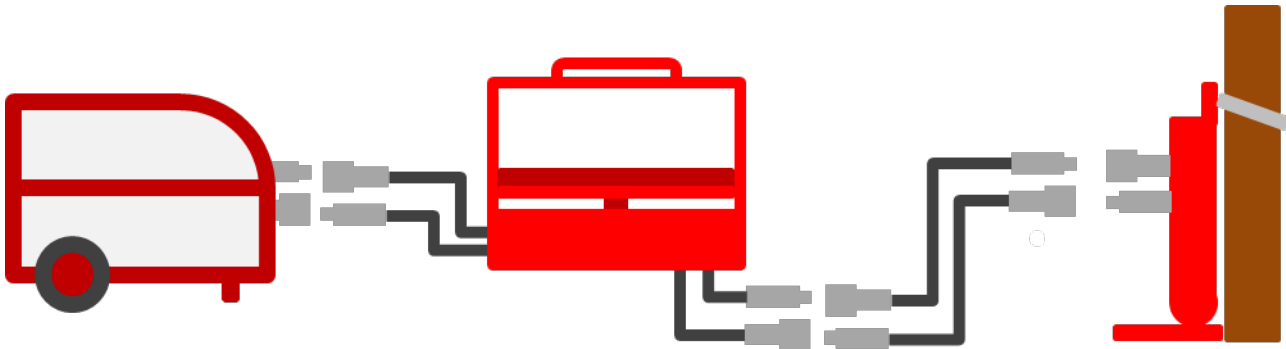

11. Move the On/Off lever to the Off position.

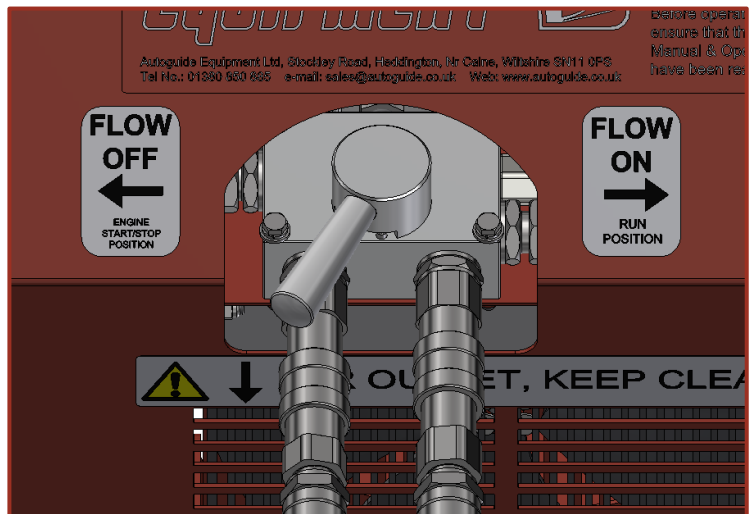

12. Start the powerpack, and move the lever to the *On* position.

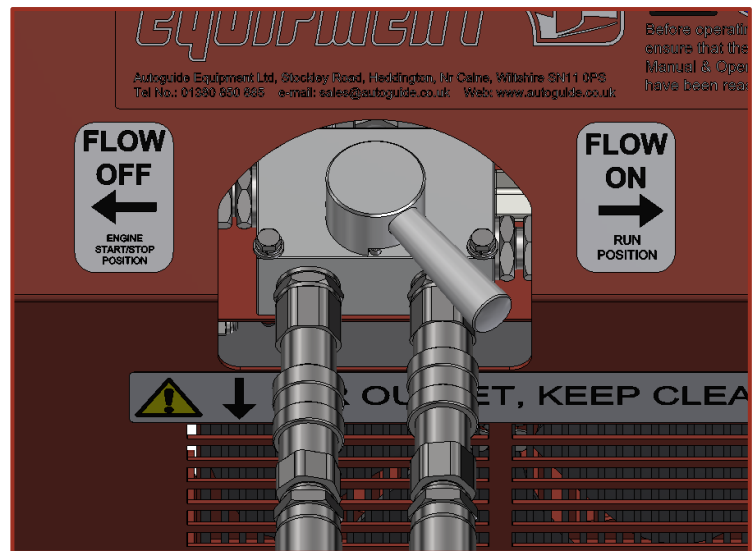

13. Using the foot pedal cycle the ram through its full extents 10 time to remove any air from the system.

Ensure that:

Right foot pedal (Forward arrow) extends the ram

Left foot pedal (Back arrow) retracts the ram

If this is not the case check hydraulic connections and re-test.

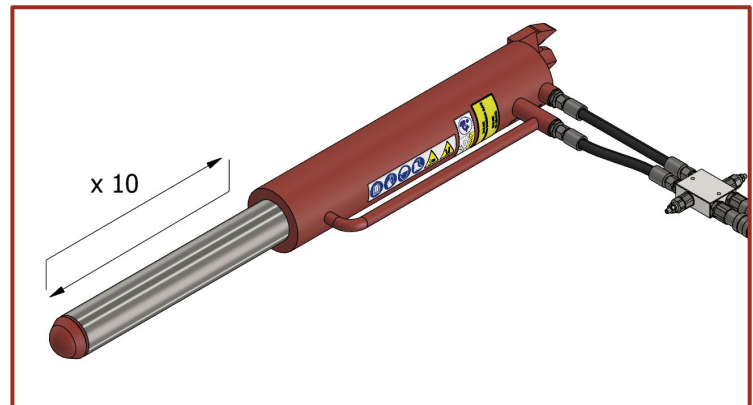

Pole Extraction with Pole Erection Unit Lorry

1. Place the baseplate with its 'cut-out' against the pole, making sure that there is adequate support underneath.

Voids should be filled before use.

Ensure the pole doesn't have blocks fitted.



2. Inspect the chain for any sign of wear or damage before use.



The Chain is specifically designed to work with this Pole Jack ONLY. It must not be used for any other lifting operation. DO NOT use any other chain.

3. Place the chain around the pole, approx. 750mm above the ground with the loose end through the reeveable link and pull tight.



4. Locate the ball-end of the ram into the socket of the baseplate, ensuring the hoses face away from the pole.

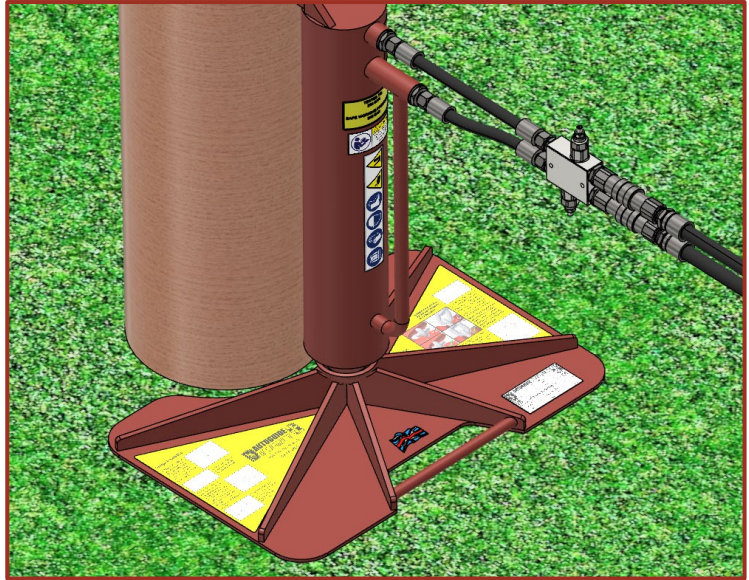

5. Locate the chain through the clutch plate on top of the pole jack. The chain must be sitting fully in the cut out with the next link perpendicular and fully seated on the curved face.

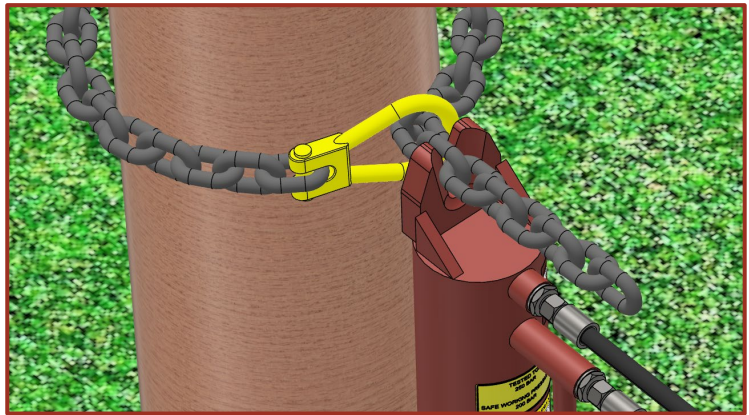

The images below show the chain fully engaged in the clutch plate. The chain link (left images) must be fully in the slot and the chain link (right images) be orientated correctly and have full contact with the hardened steel groove.

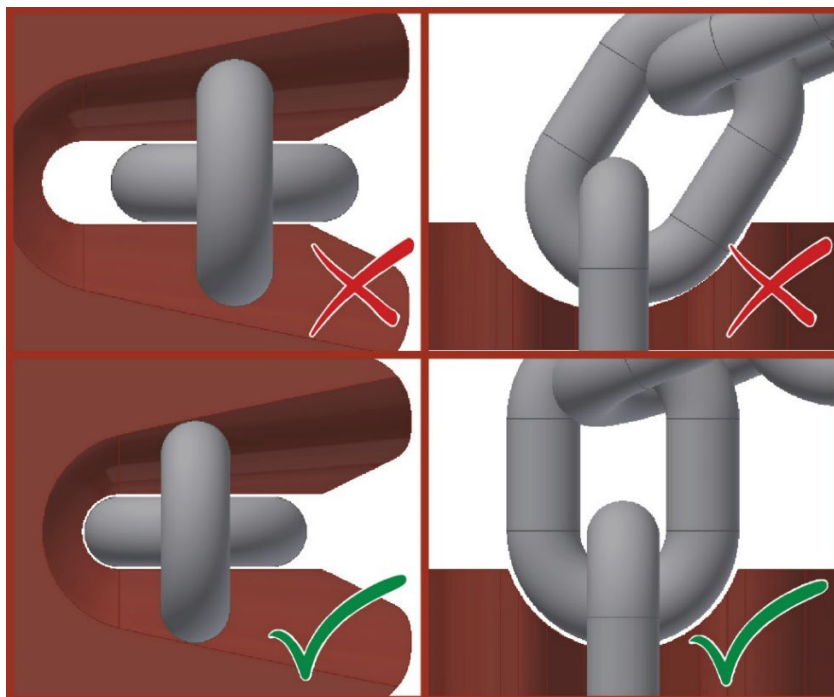



The pole jack must be used in conjunction with a crane or similar that supports the pole, prior to extracting with the pole jack.

6. Ensuring all bystanders are clear, operate the hydraulic supply to extend the ram and extract the pole.
7. Once the ram has reached its extents, retract ram and allow the chain to slide down the pole for the second pull.
8. Check the chain engagement in the clutch and repeat pull.



9. When complete, fully retract ram and then extend 10mm. Remove the pressure in the line and disconnect the couplers.

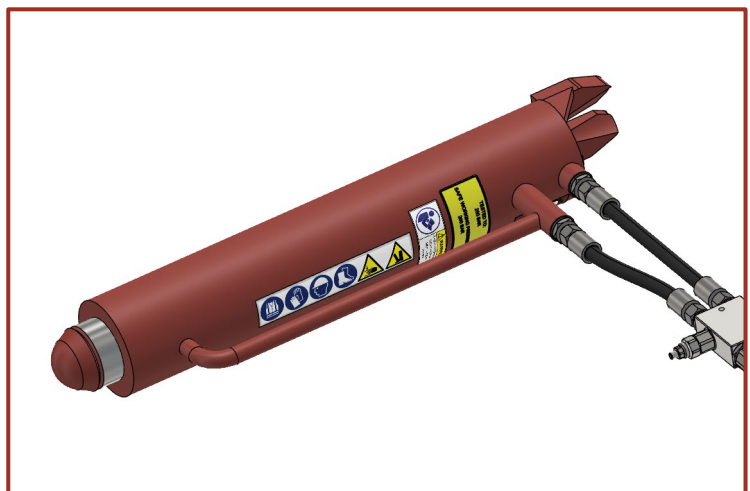

Pole Extraction with Powerpack and Foot Pedal

1. Place the baseplate with its 'cut-out' against the pole, making sure that there is adequate support underneath.

Voids should be filled before use.

Ensure the pole doesn't have blocks fitted.



2. Inspect the chain for any sign of wear or damage before use.



The Chain is specifically designed to work with this Pole Jack ONLY. It must not be used for any other lifting operation. DO NOT use any other chain.

3. Place the chain around the pole, approx. 750mm above the ground with the loose end through the reeveable link and pull tight.



4. Locate the ball-end of the ram into the socket of the baseplate, ensuring the hoses face away from the pole.

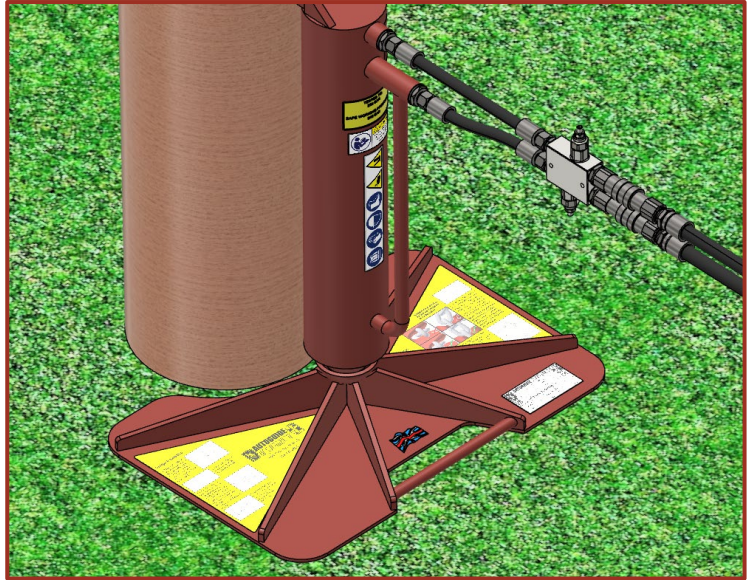

5. Locate the chain through the clutch plate on top of the pole jack. The chain must be sitting fully in the cut out with the next link perpendicular and fully seated on the curved face.

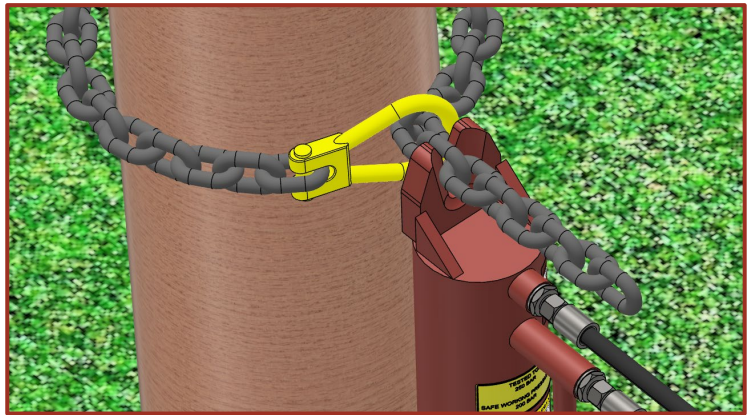

The images below show the chain fully engaged in the clutch plate. The chain link (left images) must be fully in the slot and the chain link (right images) be orientated correctly and have full contact with the hardened steel groove.

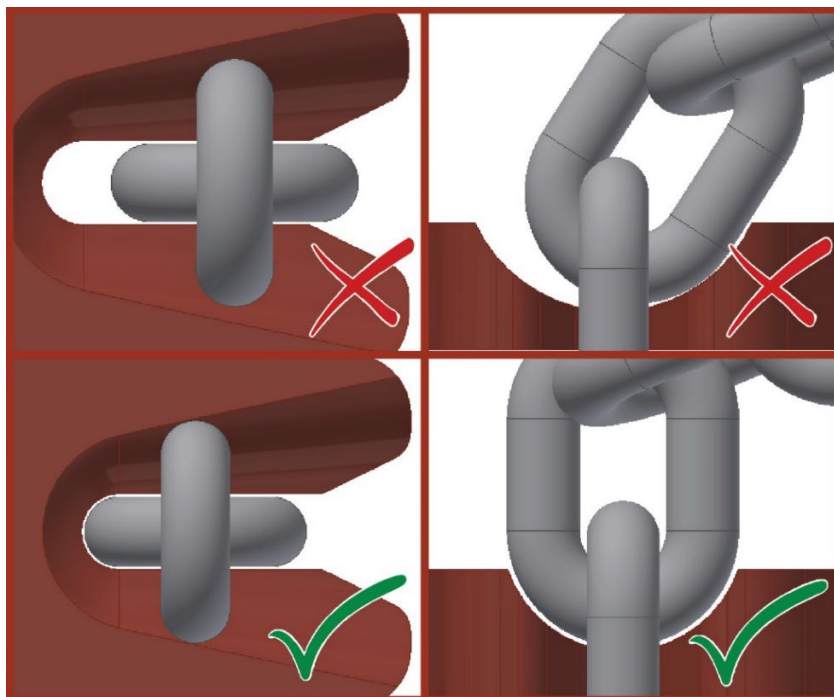



The pole jack must be used in conjunction with a crane or similar that supports the pole, prior to extracting with the pole jack.

6. Start the hydraulic power pack and switch on the hydraulic flow.

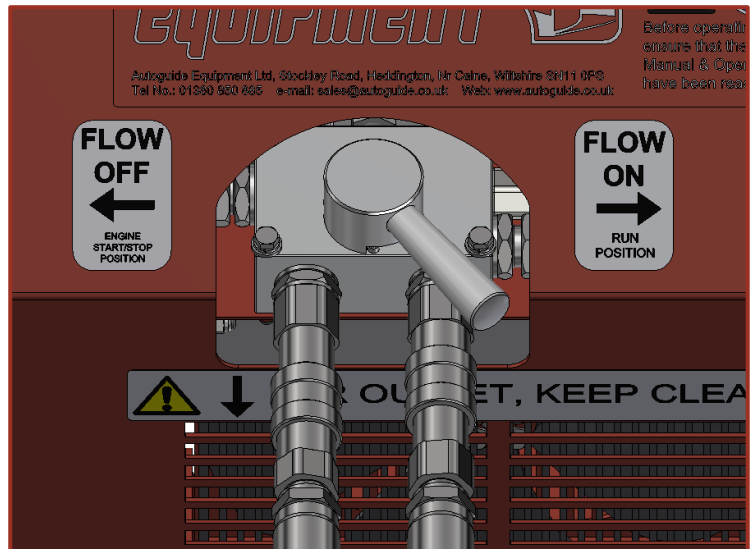

7. Ensuring all bystanders are clear, press on the right side (Forward arrow) of the foot pedal to extend the ram and extract the pole.



8. Once the ram has reached its extents, retract the ram by press on the left side of the foot pedal (Back arrow). Allow the chain to slide down the pole for the second pull.

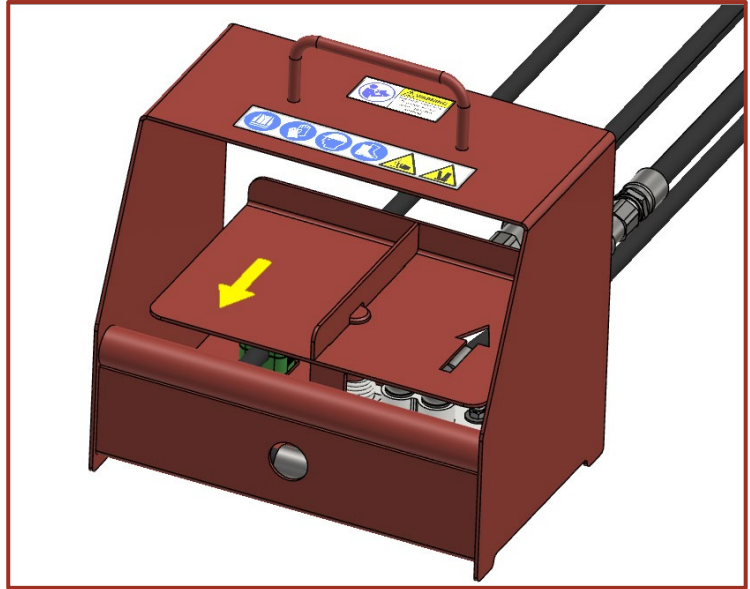

9. Allow the chain to slide down the pole for the second pull.
10. Check the chain engagement in the clutch and repeat pull.

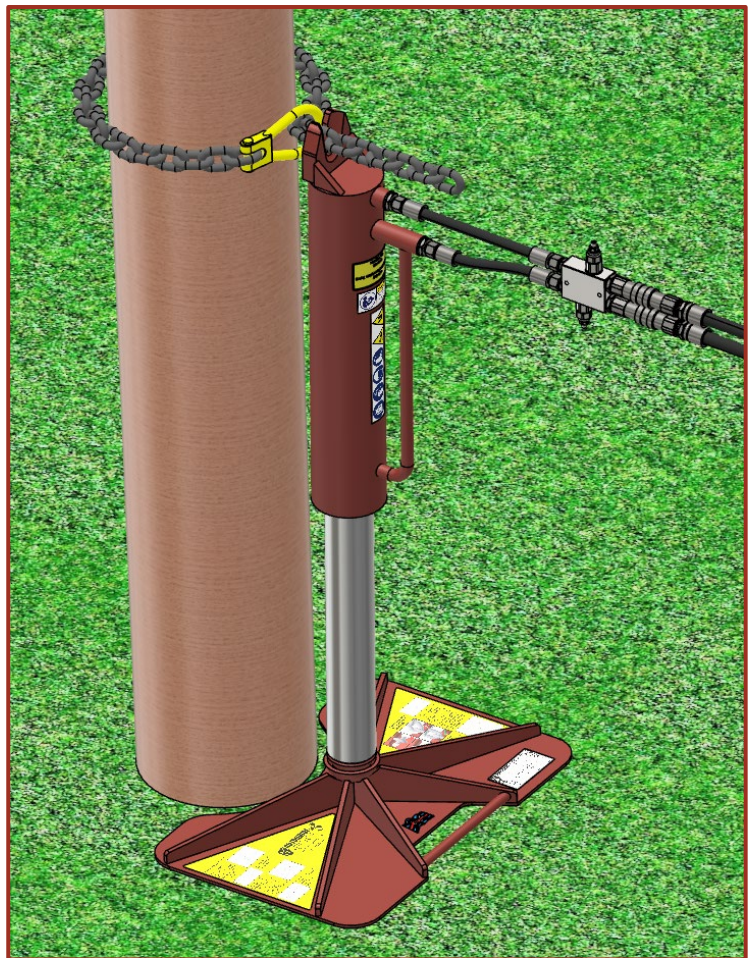

11. When complete, fully retract ram and then extend 10mm. Remove the pressure in the line and disconnect the couplers.

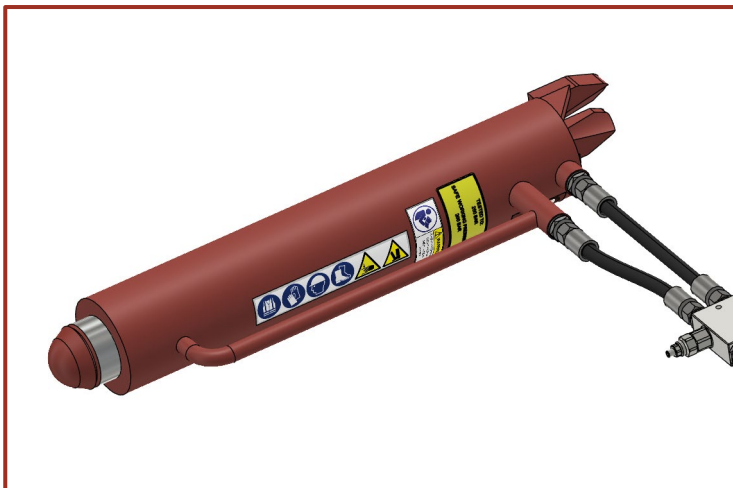

12. Turn of the hydraulic flow and switch off the powerpack

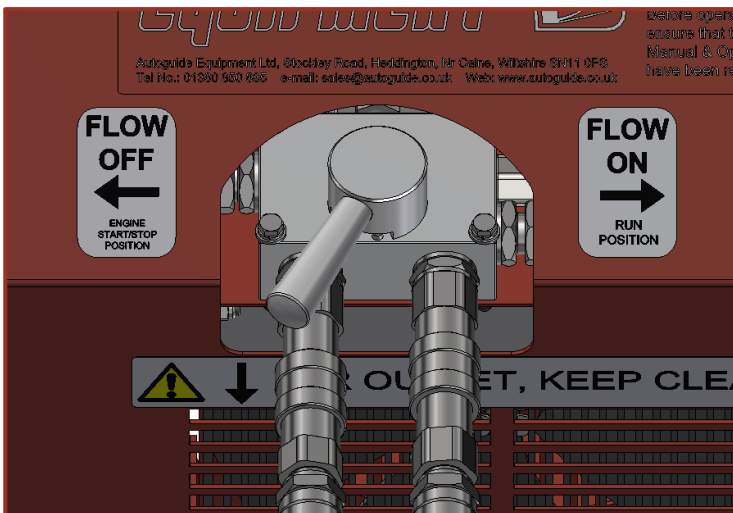

13. Operate the foot pedal in both directions to remove the pressure in the line and disconnect the couplers.



SERVICE INFORMATION

Service Schedule

The service schedule of machine items is as follows:

Service Item		Service Interval			
		10 Hours <i>Daily</i>	50 Hours <i>Weekly</i>	200 Hours <i>Monthly</i>	1000 Hours <i>Annually</i>
Hydraulics	Hydraulic Oil Level	Visual Inspection			Change
	Hydraulic Hoses	Visual Inspection			Thorough Examination
	Quick Couplers	Visual Inspection			
Other	Fasteners	Visual Inspection		Re-Torque	
	Clips and Pins	Visual Inspection			
	Chain	Visual Inspection		Inspect	Thorough Examination
	Chain ID Tags	Visual Inspection			
	Baseplate	Visual Inspection		Inspect	Thorough Examination
	Hydraulic Ram	Visual Inspection		Inspect	Thorough Examination

Daily Check Sheet

Pole Jack Daily Check Sheet

Serial No. _____ Date _____
Name _____ Signature _____

Item	Description	Tick
Hydraulics	<i>All hoses in good condition. No leaks</i>	
Quick Couplers	<i>Couplers in good condition and free from dirt</i>	
Bolt Torque	<i>All tight and present. No signs of corrosion.</i>	
Clips and Pins	<i>All pins present, in good condition and functioning as designed</i>	
Chain	<i>In good condition, no damaged or broken links</i>	
Chain ID Tags	<i>In Place, intact and legible</i>	
Baseplate	<i>In good condition, handle in place, no bowing of plate, no broken welds.</i>	
Hydraulic Ram	<i>No chips or scratches on rod, seal in good condition, no leaks fitting present and tight.</i>	
Foot Pedal (Option)	<i>Free from damage, no leaks, no obstruction to pedal movement.</i>	

Bolt Tightening

Due to the nature of the environment in which the 400H is used, it is possible the bolts can work loose during operation. It is therefore critical that all bolts and grub screws are re-torqued at regular intervals.

If tightening the bolts please use the torque values listed in the table below.

Bolt Size	Tightening Torque (Nm)		
	Hex Head Bolt Grade 8.8 – Zinc Plated	Cap Head Bolt Grade 12.9	Bolt in Aluminum Tapped hole
M6	8	16	6
M8	20	40	17
M10	40	80	33
M12	70	140	60
M14	112	225	94
M16	175	350	-
M18	241	480	-
M20	341	680	-
M24	590	1150	-
M30	1171	2300	-

Hydraulic Oil

The machine is powered by Hydraulic Oil. Clean oil and filters are essential for reliability and performance.

The machine runs on **HLP 46 Grade Hydraulic Mineral Oil**. Ensure the crane is using the same grade of oil.

TROUBLESHOOTING

Symptom	Possible Cause	Action
No movement of ram	No oil flow	Check that quick release couplers are correctly engaged and locked together. Check the hydraulic system is operating correctly and has sufficient oil of the correct grade.
	Broken or damaged ram	Return to Autoguide Equipment for assessment.
Slow movement	Insufficient oil flow	Check that hydraulic system is operating correctly and has sufficient oil of the correct grade.
	Hoses too small for flow	Ensure correct hydraulic feed hoses are being used to reduce back pressure.
	Broken or failing ram	Return to Autoguide Equipment for assessment.
Ram stalls during operation	Pressure relief valve faulty or set too low	Check Pressure Relief valve to ensure sufficient pressure is allowed before relieving.
	Restricted oil flow	Check for damaged or incorrect hydraulic hoses and connections.
	Blocked hydraulic filter	Change hydraulic filter and oil.
	Back pressure too high	Ensure correct hydraulic feed hoses are being used to reduce back pressure.
	Pump damaged or failing	Check hydraulic flow to ensure sufficient flow from pump.
	Broken or damaged ram	Return to Autoguide Equipment for assessment.
Movement Jerky	Cold oil	Let hydraulic system run with the flow on to allow time for the engine and oil to warm up
	Air in pipes	Check oil in reservoir.
Oil leaks	Loose Fittings	Check and tighten hydraulic fittings.
	Damaged Hoses	Replace if leaking. Ensure suitable hose of the correct pressure rating is used.
	Pressure Too High	Ensure hydraulic supply is suitable for the machine specifications and that they do not exceed the maximum flow and pressure on the data plate.

Please contact Autoguide Equipment if there are any issues that cannot be resolved with the advice above.



AUTOGUIDE EQUIPMENT



SERVICING

Autoguide Equipment prides itself not only on the quality of its products but also on the comprehensive support it provides to you, our customers. As part of our commitment to ensuring maximum performance and longevity, Autoguide offers servicing for all products within our extensive range. Whether it's hydraulic powerheads, augers, or other machinery, customers can rely on Autoguide for top-notch maintenance.

One of the standout features of Autoguide's servicing is its flexibility. Customers have the option to have their equipment serviced either on-site or at Autoguide's well-equipped workshop. This flexibility ensures minimal disruption to operations, as customers can choose the option that best suits their needs and schedule. Whether it's a routine check-up or addressing specific issues, Autoguide's team of skilled technicians is dedicated to delivering prompt and reliable servicing to keep equipment running smoothly.

With Autoguide Equipment, customers not only invest in cutting-edge machinery but also in the assurance of ongoing support and maintenance, maximising the value and efficiency of their equipment over the long term.



+44 (0)1380 850885



WWW.AUTOGUIDE.CO.UK



END OF LIFE

When the machine reaches the end of its useable lifetime it is important that the independent elements of the machine are reused, recycled or disposed of suitably.

Component	What to do?
Metals	All metals should be recycled with an appropriate scrap metal merchant, preferable sorted into metal type.
Electronics	All electrical components should be recycled at an appropriate facility according to the WEEE Directive and Regulations 2013
Oils	Oil waste is classed as Hazardous and therefore must be stored separately and according to legal regulations (that differ dependent on country). It must be disposed of by a suitable Waste Oil collection company.
Hydraulic Hoses	Hydraulic hoses should be drained of oil, metal ends removed and then recycled with a suitable specialist recycling company. Metal ends can be sent to metal recycling centres.
Plastics	All plastics should be sorted into recyclable and non recyclable and then either sent to suitable recycling facilities or landfill.

WARRANTY

Coverage

Autoguide Equipment warrants the product against defects in materials and workmanship for 12 months from the date of purchase, applicable to the original purchaser only, when paid in full.

What's Covered

We will repair or replace, at our discretion, any defective parts or the entire product during the warranty period, free of charge determined as defective by Autoguide. The customer is responsible for returning the product for warranty inspection to the Autoguide's facility. Parts should not be delivered without the prior agreement from Customer Services. Autoguide are not liable for any associated costs relating to a warranty failure. Parts repaired or replaced by Autoguide are then covered by this warranty for the remainder of the original warranty as if such parts were original parts.

Exclusions

Damage resulting from misuse, abuse, unauthorised modifications, normal wear and tear, or external causes is not covered. This warranty is void if any attempt is made to make field repairs unless these have been preapproved, or the data plate has been removed.

Obtaining Service

Contact Customer Services for warranty service, providing proof of purchase, product serial number (located on the data plate) and a description of the problem.

Limitation of Liability

Autoguide Equipment shall not be liable for incidental, consequential, or special damages arising from product use.

General Terms & Conditions: Refer to our standard T&C's <https://www.autoguideequipment.co.uk/tcs-ag-v2-8>

SPARE PARTS

55486 - Pole Jack Kit

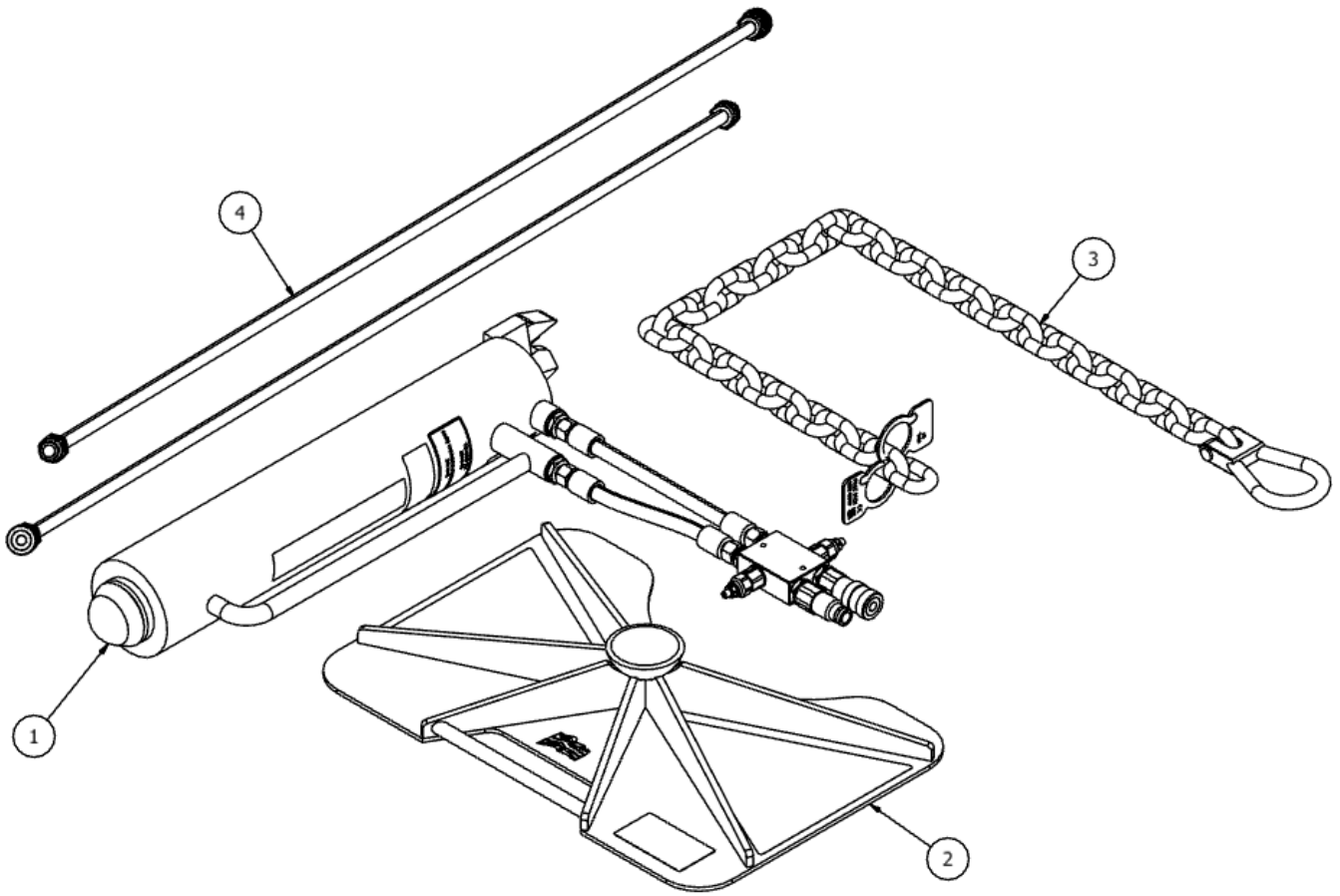

No.	Code	Description	Quantity
1	55482	Pole Jack Ram	1
2	53388	Pole Jack Baseplate	1
3	53869	Pole Jack Chain	1
4	50788	Pole Jack Feed Hoses	1

55482 - Pole Jack Ram

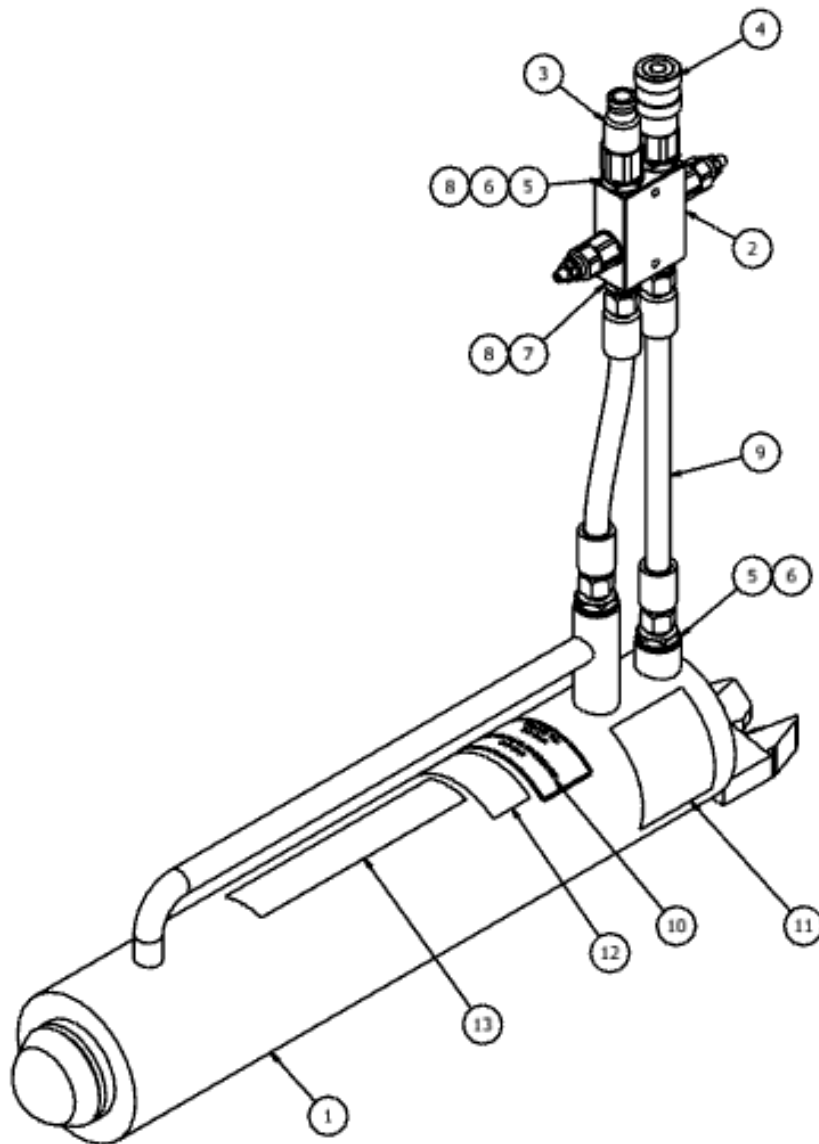

No.	Code	Description	Quantity
1	50785	Pole Jack Ram Weld Assembly	1
2	13518	Relief Valve	1
3	03624	Coupler 3/8" Male	1
4	02401	Coupler 3/8" Female	1
5	01096	Adaptor MM 3/8" to 1/2"	2
6	02182	Seal 1/2"	2
7	01095	Adaptor MM 3/8"	4
8	01812	Seal 3/8"	6
9	51330	Pole Jack Hose Kit	1
10	53398	Pole Jack Ram Decal	1
11	53788	Chain Cleat Decal	1
12	54836	Read Operating Manual Decal	1
13	55030	Pole Jack Safety Decal	1

55485 –Pole Jack Lorry Kit

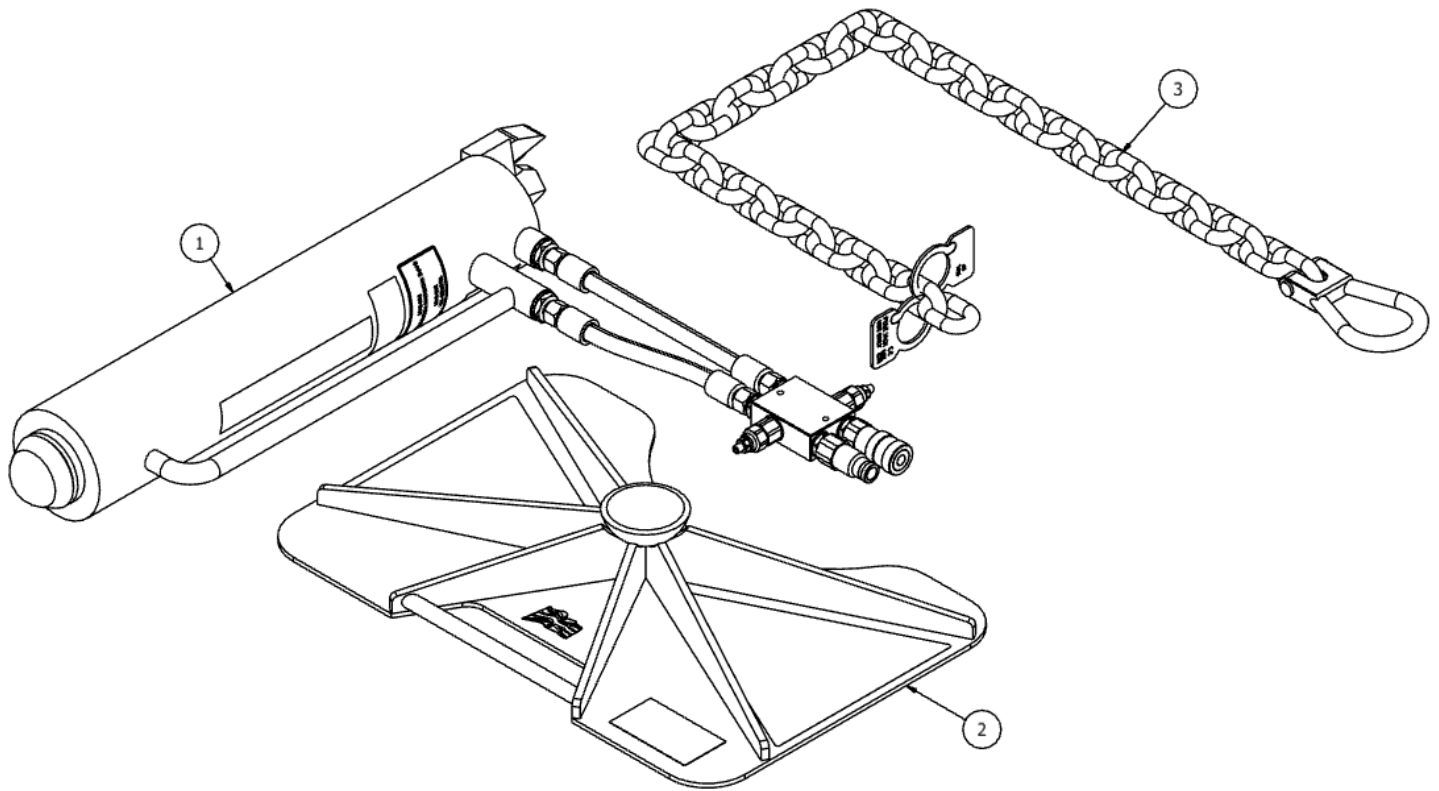

No.	Code	Description	Quantity
1	55482	Pole Jack Ram	1
2	53388	Pole Jack Baseplate	1
3	53869	Pole Jack Chain	1

49235 – Foot Pedal Assembly

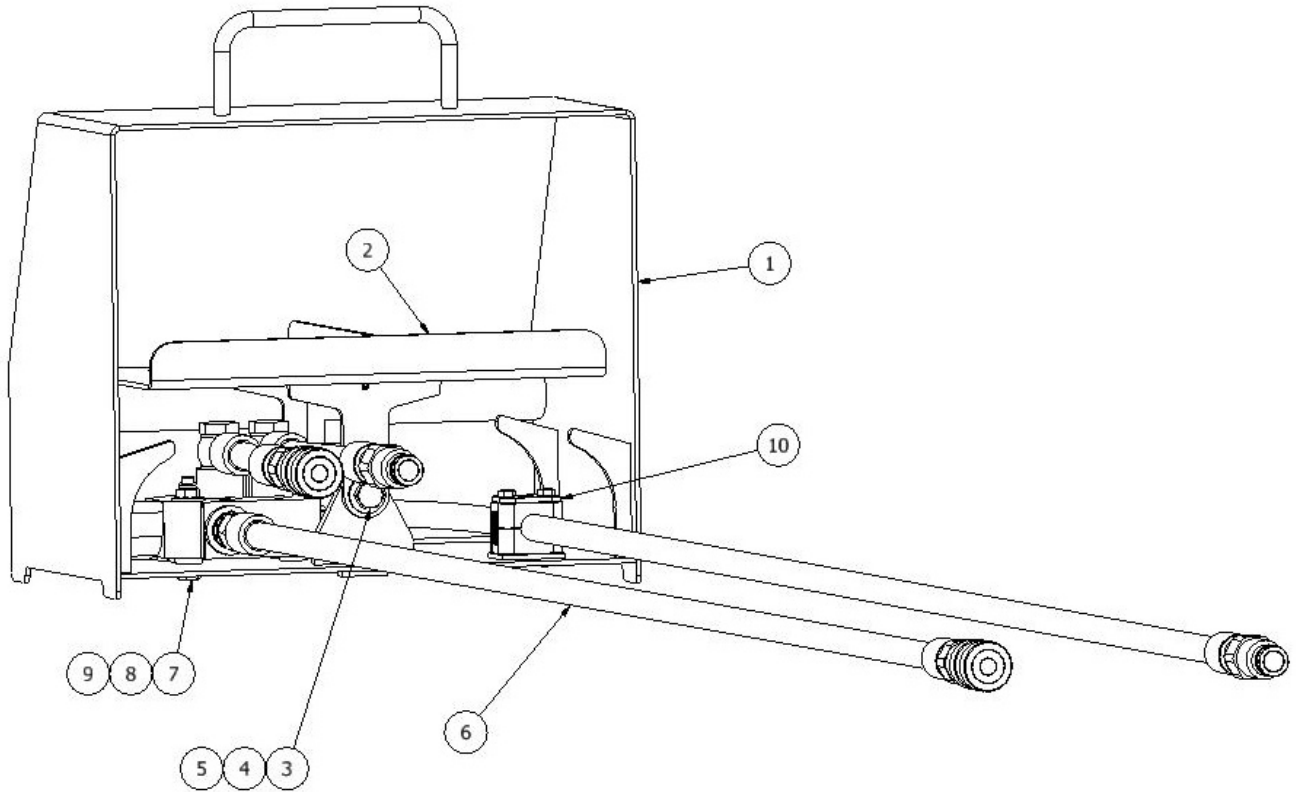

No.	Code	Description	Quantity
1	49237	Pedal Base	1
2	49242	Pedal	1
3	02997	Bolt Hex M10 x 35	2
4	02702	Washer Flat M10 Form C	6
5	02523	Nut Nyloc M10	2
6	49236	Foot Pedal Hydraulics	1
7	02454	Bolt Hex M8 x 60	2
8	02977	Washer Flat M8 Form C	4
9	02496	Nut Nyloc M8	2
10	11078	Stauff Clamp	1
11	54836	Read Operating Manual Decal	1
12	55030	Pole Jack Safety Decal	1

49236 – Foot Pedal Hydraulics

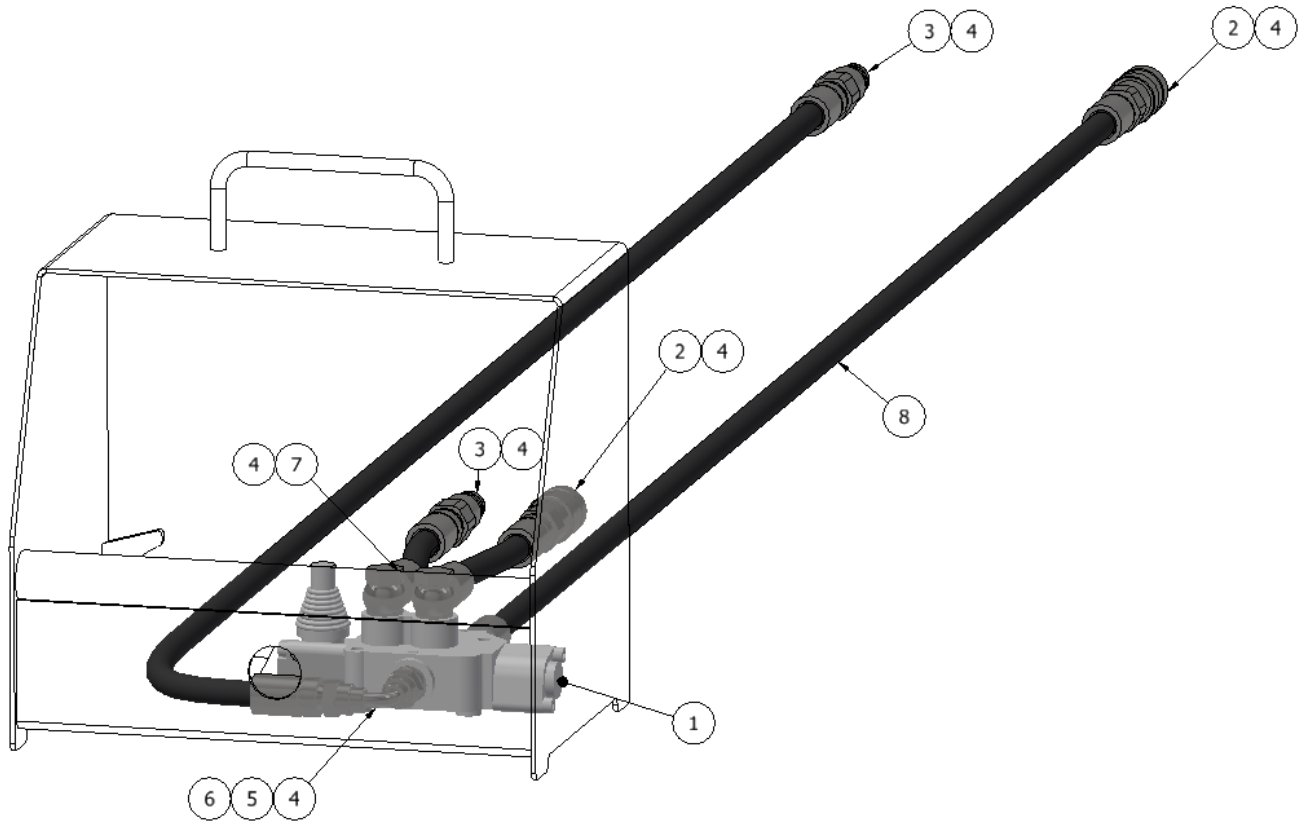

No.	Code	Description	Quantity
1	02978	Valve Spool	1
2	02401	Quick Coupler Female	2
3	03624	Quick Coupler Male	2
4	01812	Seal Bonded	10
5	01095	MM Adaptor	2
6	04389	Swept Elbow	1
7	05601	Banjo Bolt	2
8	49226	Foot Pedal Hose Kit	1

49226 – Foot Pedal Hoses

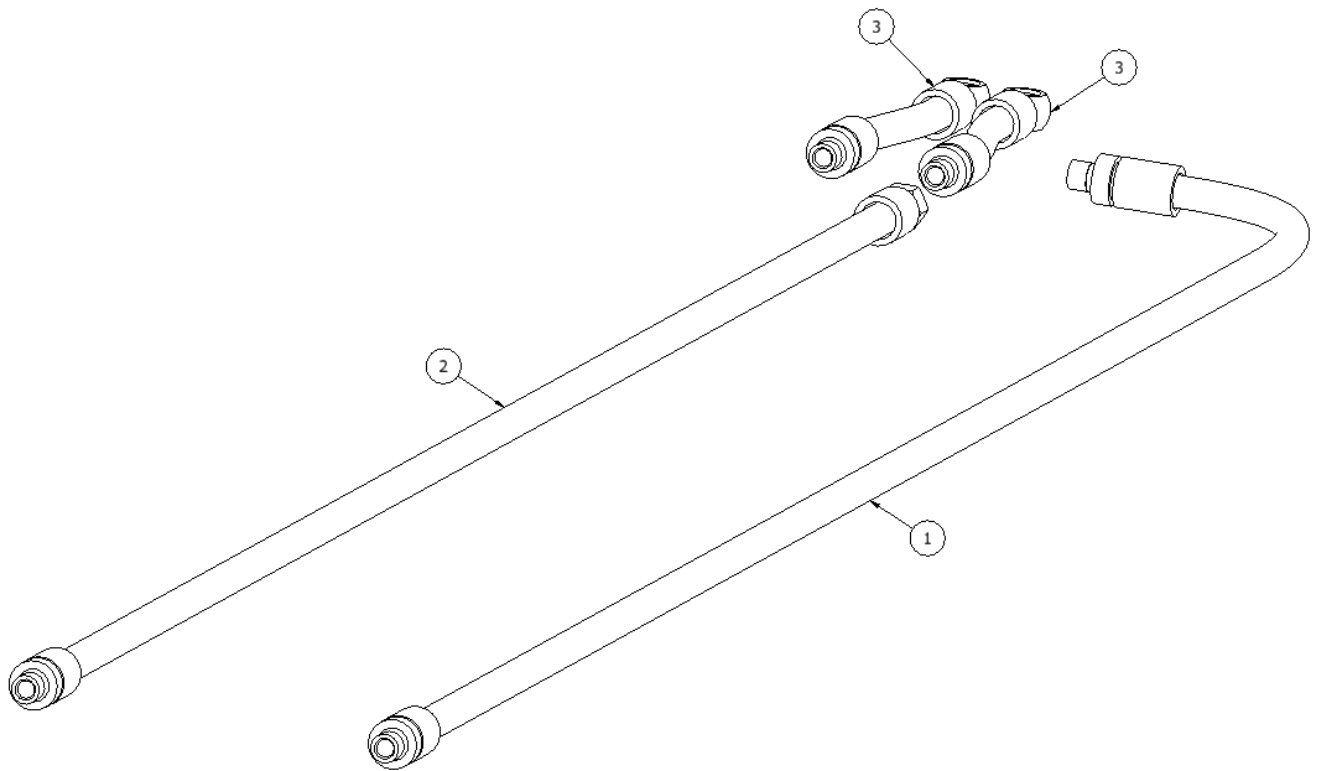

No.	Code	Description	Quantity
1	49227	Hose 1	1
2	49228	Hose 2	1
3	49229	Hose 3	2

50788 – Feed Hoses

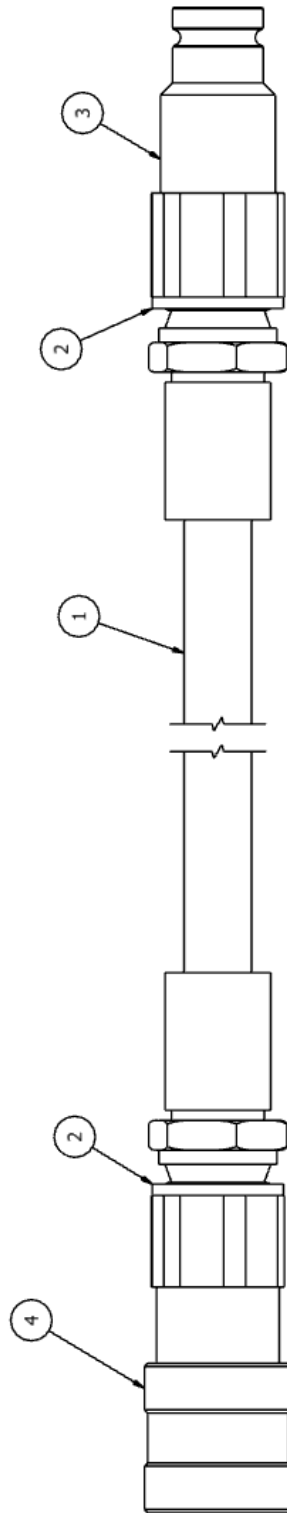

No.	Code	Description	Quantity
1	50790	Feed Hose	1
2	02182	Seal Bonded	2
3	09206	Quick Coupler Male	1
4	09191	Quick Coupler Female	1



Autoguide Equipment
Stockley Road
Heddington
Nr. Calne
Wiltshire SN11 0PS
England
Tel: +44 (0) 1380 850885
Website: www.autoguide.co.uk

