



AUTOGUIDE EQUIPMENT



50,000PXV QUICK HITCH

MANUAL SPARE PARTS

Autoguide Equipment Ltd
Stockley Road,
Heddington, Calne,
Wiltshire, UK,
SN11 0PS
+44(0)1380 850885
www.autoguide.co.uk

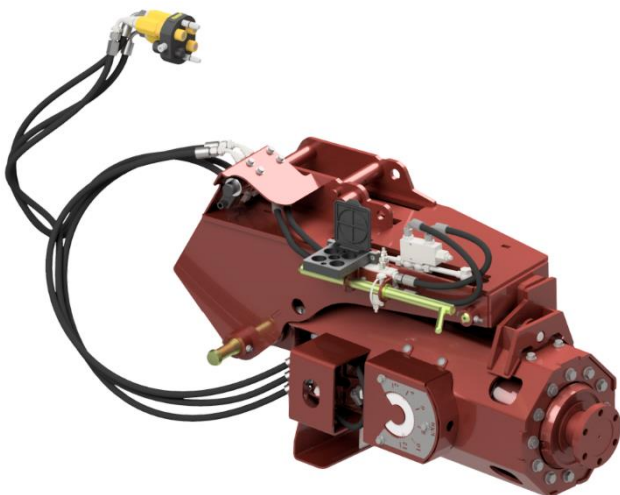

These instructions give safety and operations information regarding the use of a Crane Mounted Auger Powerhead, Quick Hitch and Hydraulic Fold-Up bracket supplied by Autoguide Equipment. They contain the relevant information for products:

Product Code	Description	Maximum Output Power (Nm)	Weight (Kg)
27649	50,000PXV Powerhead	12,000	200
41700	Fold Up Bracket	-	90
34312	Quick Hitch Assembly	-	37
30733	Quick Hitch Latch Pin	-	2

	Part Number
Boom Clamp Plates	
Stowage Bracket	
Stowage Frame	

To ensure optimum results when operating this equipment it is very important to read this manual carefully, the information will prepare you to do a better, safer job.

Before operating the machine you should familiarise yourself with the instructions in this manual. Incorrect use can lead to damage which is not covered by the Warranty Conditions. This may create a dangerous situation or lead to unsatisfactory results.

These operating instructions **MUST** always be made available to the person or persons operating this equipment.

To assist in the ordering of spares, or other communications with our company, the serial number of the relevant equipment supplied, has been recorded below for your information.

Model No:-

Serial No:-

Date of Delivery:-

CONTENTS

Information	3
Safety Instructions	3
Daily Check Items.....	3
Auger Selection	4
Aggressor Augers	5
Heavy Duty Augers	5
Rock Ripper Augers.....	5
Powerhead Installation	7
Principle of Operation	7
Mounting the Attachment.....	9
Pre-operation check list	12
Powerhead Operation	13
Operating the Hydraulic Fold-Up Bracket	13
Releasing the Powerhead	13
Storing the Powerhead.....	15
Drilling Holes	17
Low Speed Lock.....	17
General Principles of Operation.....	17
Dismounting the Attachment.....	19
Troubleshooting	21
End of Life	22
Spare Parts	23
27649 – 50,000PXV Auger Power Head	23
41700 – Fold Up Bracket.....	25
34250 – Fold Up Bracket Hydraulics	27
34312 – Quick Hitch Assembly.....	29
30733 – Quick Hitch Latch Pin	31
Stowage Cradle	32
Stowage Frame	34

INFORMATION

Your Powerhead has been individually built with great emphasis on quality, strength and simplicity of design and with routine care will give many years of trouble free operation.

The following instructions have been written to cover the use and maintenance of the machine. Care should be taken to ensure that you are referring to the correct section of your machine before carrying out any adjustments, or when ordering spare parts.

Like all mechanical products, regular cleaning, lubrication and maintenance will ensure a longer trouble free life. These instructions make no attempt to go beyond routine maintenance, and it is strongly advised that you contact your dealer should any major repairs become necessary.

Use only genuine service parts; non genuine parts may not meet standards required for safe and satisfactory operation.

Safety Instructions

1. Read and understand this operator's manual prior to operating the machine and keep it in a convenient place for future reference.
2. Keep untrained personnel away from the machine whilst it is in operation.
3. Keep all guards and safety devices in place.
4. Do not operate machine with guards removed.
5. Beware, pressured hydraulic oil can be very dangerous and can penetrate the skin - TAKE THE UTMOST CARE.
6. Keep hands, feet and loose clothing away from moving parts.
7. Always switch off the machine before making any adjustments or when carrying out lubrication and servicing.
8. Keep all nuts, bolts and fasteners tightened.
9. Check machine regularly for damaged or worn parts.
10. If the machine is left unattended ensure that it is locked or disabled to prevent use by untrained personnel.

Daily Check Items

1. Check the unit is properly and securely attached to the crane/excavator unit.
2. Check that all nuts and bolts are secure, mounting pins are properly retained, and all safety shields are in place. (All nuts and bolts should be checked after the first 10 hours of operation.)
3. Check the condition and security of any auger or anchor driver attachment.
4. Lubricate all grease nipples.

Auger Selection

When digging a hole it is important to know what soil type it is that the auger will be trying to penetrate. With this information the correct auger can be selected to give increased penetration and speed.

Soils are classified into 9 categories ranging from hard rock to loose silt. To determine which category will be being augured, a soil probe kit is available from Autoguide Equipment.

Class	Common Soil Type	Geological Soil Classification	Probe Values <i>in/labs (Nm)</i>	Typical Blow Count <i>in/labs (Nm)</i>
1	Sound, hard rock – Unweathered	Granite, Basalt, Massive Limestone	N/A	N/A
2	Very dense and/or cemented sands, Coarse gravel & Cobbles	Caliche (Nitrate-bearing Gravel/Rock)	750-1600 <i>(85-181)</i>	60-100+
3	Dense, Fine Sands, very hard silts & clays (may be pre-loaded)	Basalt Till, Boulder Clay, Caliche, Weathered Laminated Rock	750-1600 <i>(85-181)</i>	45-60
4	Dense sands & gravel, hard silts & clays	Glacial Till, Weathered Shale's, Schist, Gneiss & Sandstone	600-750 <i>(68-85)</i>	35-50
5	Medium dense sand & gravel; very stiff to hard silts and clays	Glacial Till, Hardpan, Marls	500-600 <i>(58-68)</i>	24-40
6	Medium dense coarse sands & sandy gravels; stiff to very stiff clays	Saprolite's, Residual Soils	400-500 <i>(45-56)</i>	14-25
7	Loose to medium dense fine to coarse sands to stiff clays and silt	Dense Hydraulic Fill, Compacted Fill, Residual Soils	300-400 <i>(34-45)</i>	7-14
8	Loose, fine sands; alluvium; loess; medium & varied clays, fill	Flood Plain Soils, Lake Clays, Abode, Fill	100-200 <i>(11-25)</i>	4-8
9	Peat, organic silts, inundated silts, fly ash, very loose sands, very soft	Miscellaneous Fill, Swamp Marsh	Less than 100	0-5

Once the soil classification is known the appropriate auger can be selected.

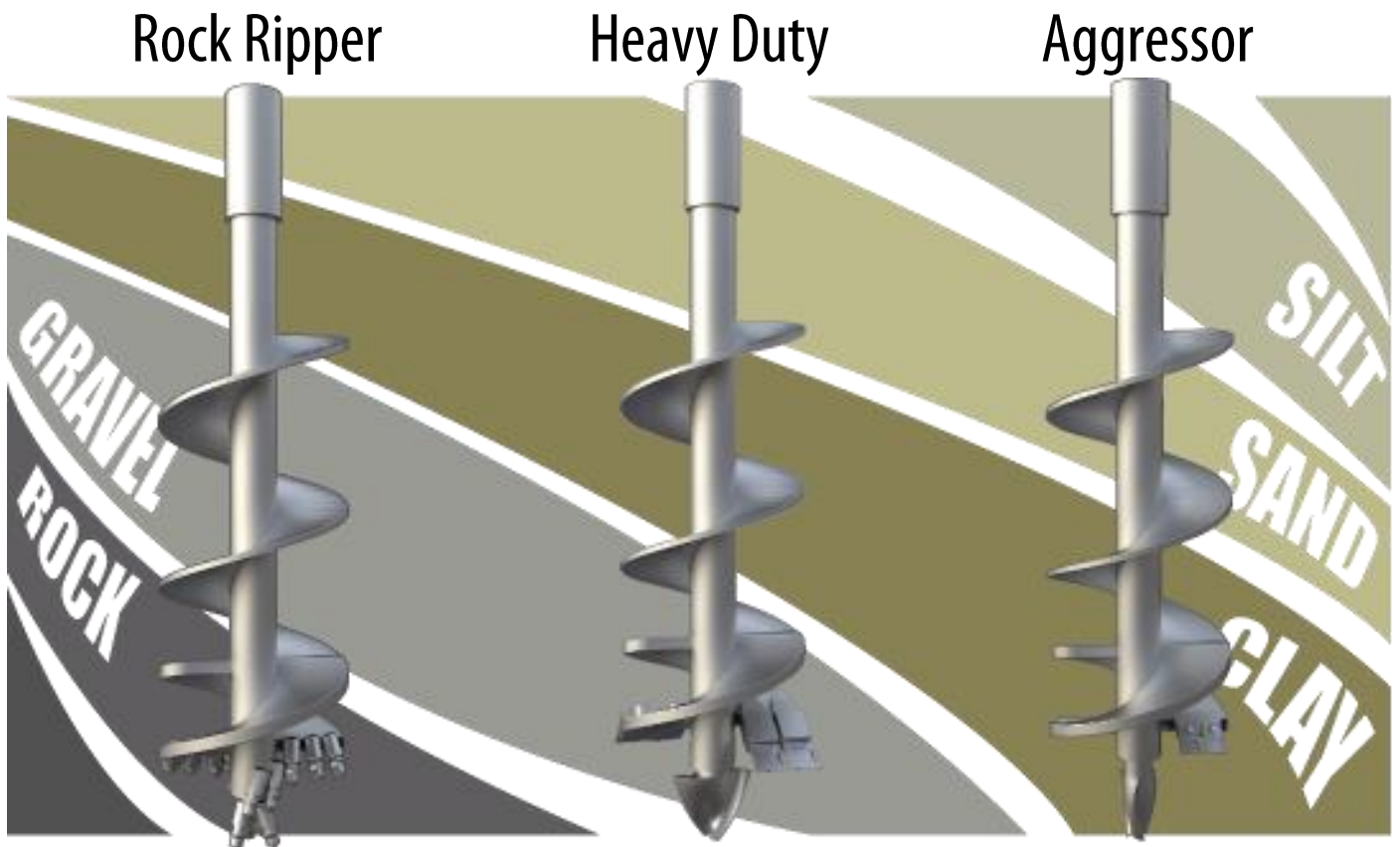

Aggressor Augers

Designed for drilling in loose soil and sand, Aggressor Augers come in 1.2m lengths, with an optional 1m extension.

These suit Powerheads with up to a maximum rated output of 4500Nm. They use a 2" hexagon socket industry standard drive. Standard teeth are bolt on drop forged high carbon steel and carbide versions are available.

Heavy Duty Augers

Designed for drilling in dense gravel and soil, Heavy Duty Augers come in 1.2m lengths, with an optional 1m extension

These suit Powerheads with up to a maximum rated output of 15,000Nm. They use a 2" hexagon or 65mm hexagon drive. Teeth are drop forged special steel or carbide tipped, retained with a rubber lock system.

Rock Ripper Augers

Designed for drilling solid rock, Rock Ripper Augers come in 1.2m lengths, with an optional 1m extension

These feature a unique computer generated tooth layout utilising self-sharpening carbide teeth which rotates in work. Whilst they do not perform well in hard clay soils, they will drill all materials up to hard concrete. Drilling performance in hard conditions depends on the

application of sufficient down force. If additional down force is require a Rockmaster hammer system is available from Autoguide.

Autoguide have a wide range of different Augers available to dig holes ranging from 6" to 36" diameter in all soil classifications. These can be both rented and purchased.

POWERHEAD INSTALLATION

The safe operation of this equipment is the responsibility of the operator, who should be familiar with the lifting process, the power unit and all safety practices before starting operations.

The Autoguide 'Quick Hitch' has been designed to enable 'attachments' for lorry-mounted cranes to be fitted or changed more easily utilising hydraulic power from the base unit.

SAFETY: Never place any part of your body where it could get trapped, crushed or injured. This quick hitch is designed to make attachment of accessories to cranes safer than existing methods, utilising hydraulic power where manual intervention was previously necessary. Careful operation and a common sense approach will ensure you achieve these objectives.

IMPORTANT: The 'Quick Hitch' unit is a welded construction and therefore cannot be dismantled for servicing. In the unlikely event that a problem arises, the unit must be returned to Autoguide Equipment Ltd for any repair or service work.

Principle of Operation

The Hitch comprises two separate assemblies, one of which is part of the attachment and the other is bolted to the crane boom (Assembly 2).

Assembly 1 consists of two side plates **A** supporting two fixed cross bars **B**, one of which has a free rotating outer sleeve **C**.

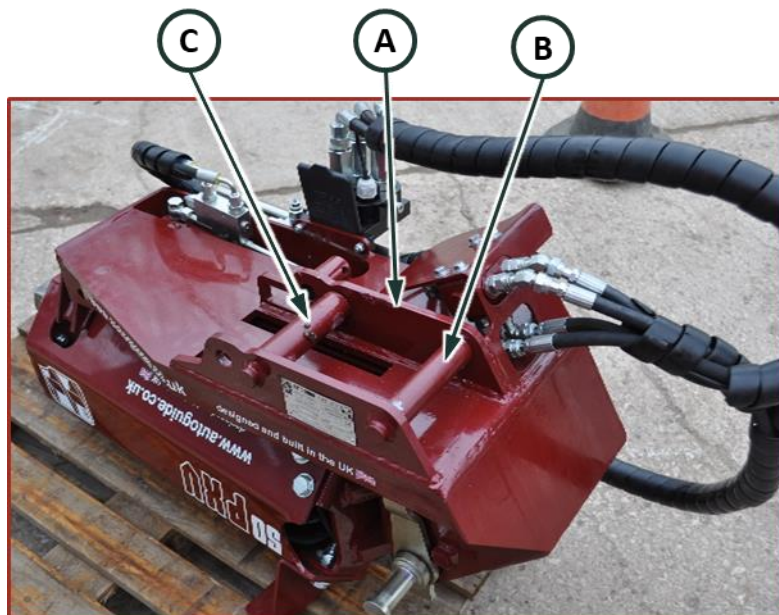

Assembly 2 comprises a fixed jaw **D**, a rotating claw **E**, a safety catch **F**, a safety pin **G**, a hydraulic cylinder **H**, locking/isolator valve **I**, and handle **J**.

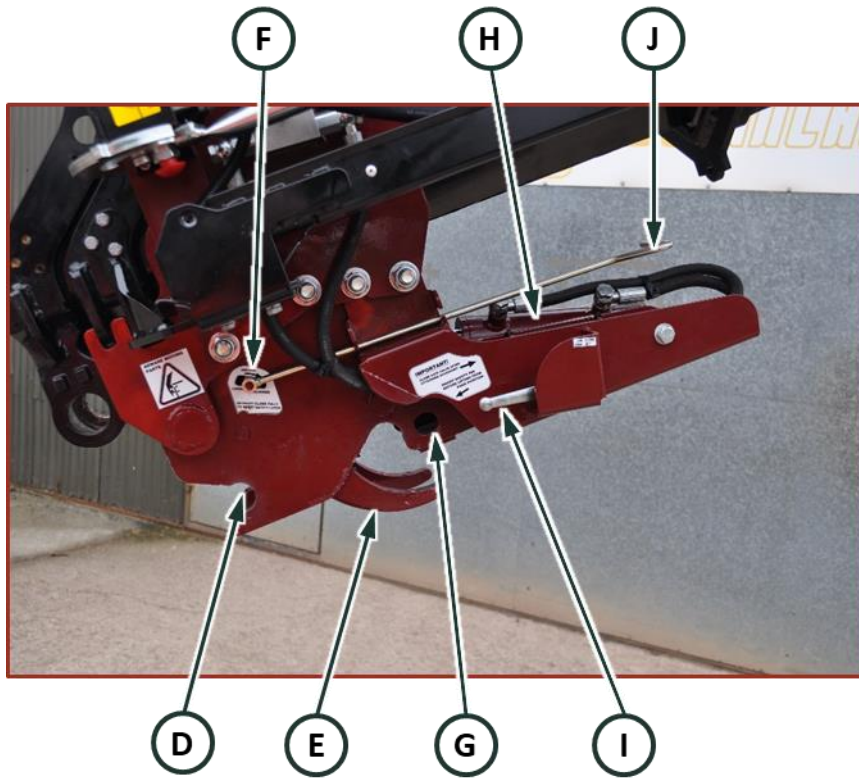

Note: The hitch may only be operated with the hydraulic/electrical (Faster) coupler disconnected

Mounting the Attachment

1. The attachment must be positioned on a suitable flat surface and aligned such that its mounting plate is presented at a suitable angle to the crane boom.

IMPORTANT: Do not at this stage connect the 3-way hydraulic coupler.

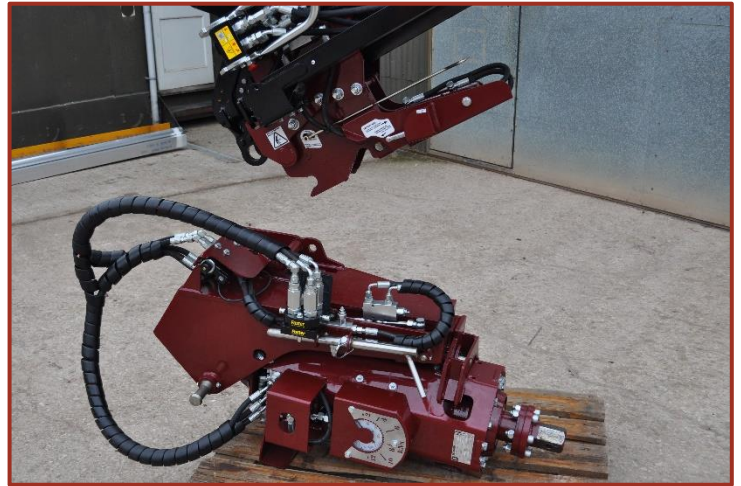

2. Set the lock valve I to OPEN (Handle horizontal).



3. If the rotating claws **E** are closed, unlock the safety latch **F** by pulling the handle **J** out. It may be necessary to 'pressurise' the claws into the closed position first, then rotate the claws to the fully open position.

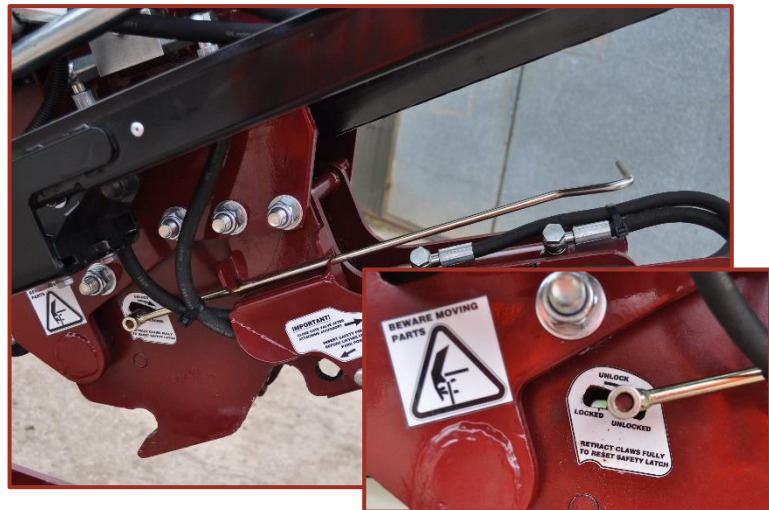

4. Move the crane so that the fixed jaws **D** capture the attachment pin **B**.

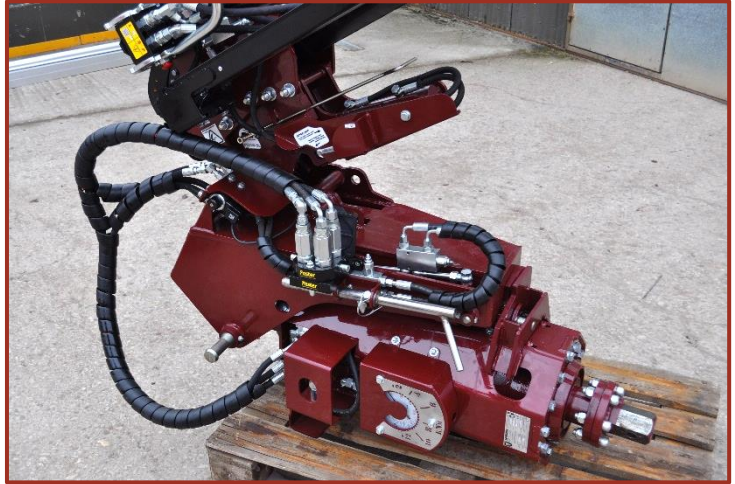

5. Extend the crane boom, tipping the Powerhead forwards to position the second locking pin so that it can be secured by the claws.



6. Operate the hydraulics to close the claws around the second shaft **C**, lifting the crane boom slightly to aid the movement of the claws. This process is not visible but a claw rotates to secure the second shaft.



7. Once the claws are fully engaged the safety catch will click into the locked position.



8. Fit the safety pin **G** and close the lock valve **I**.

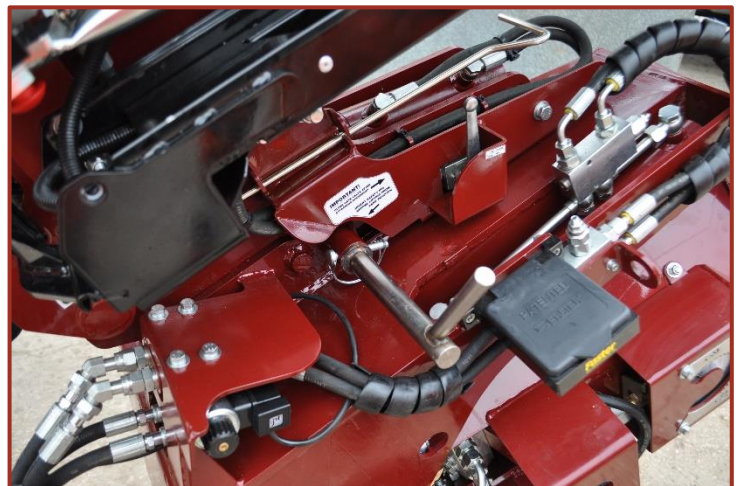

9. Connect the hydraulic/electrical 3-way connector ('Faster Coupler') to supply power to the attachment.

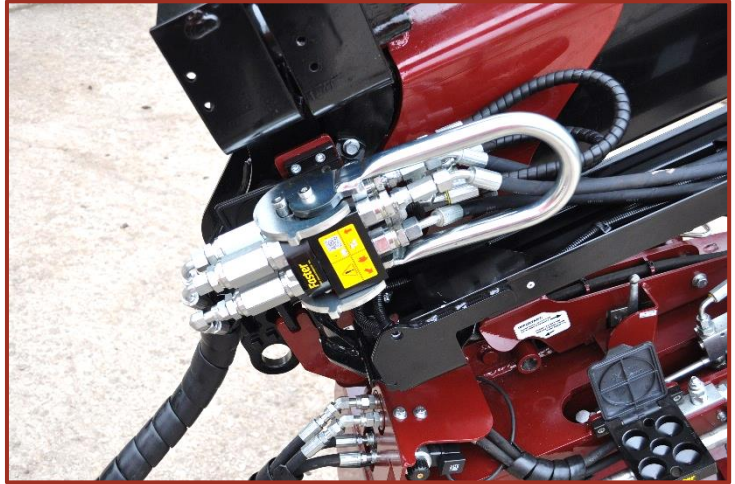

10. Operate the cranes' auxiliary circuit to test the Powerhead and ensure rotation.
11. Raise and lower the crane boom to make sure that there is no interference with the boom or swivel bracket.
12. Once complete, lower the auger unit to the ground while not in use.

Pre-operation check list

1. Keep bystanders away from all rotating attachments.
2. Ensure you are aware of the environment you are working in; be aware of overhead cabling and other utilities services.

POWERHEAD OPERATION

Operating the Hydraulic Fold-Up Bracket

Releasing the Powerhead

1. Position the crane boom angled towards the ground as shown.

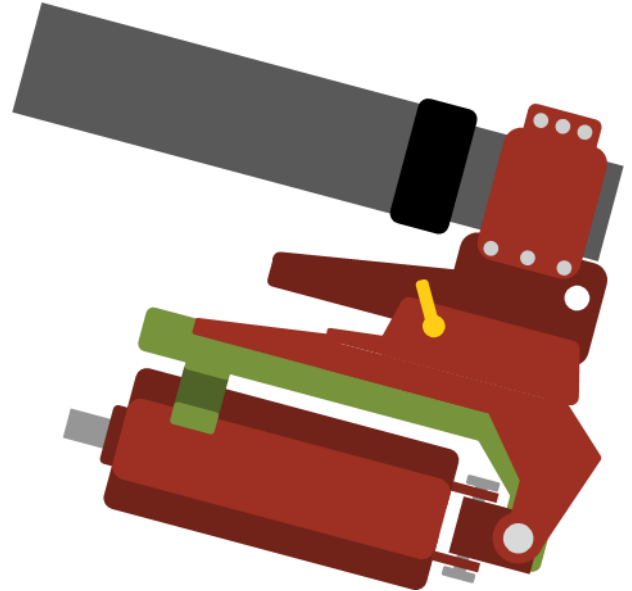

2. Slowly lower the catcher arm through 90° by operating the hydraulic circuit.

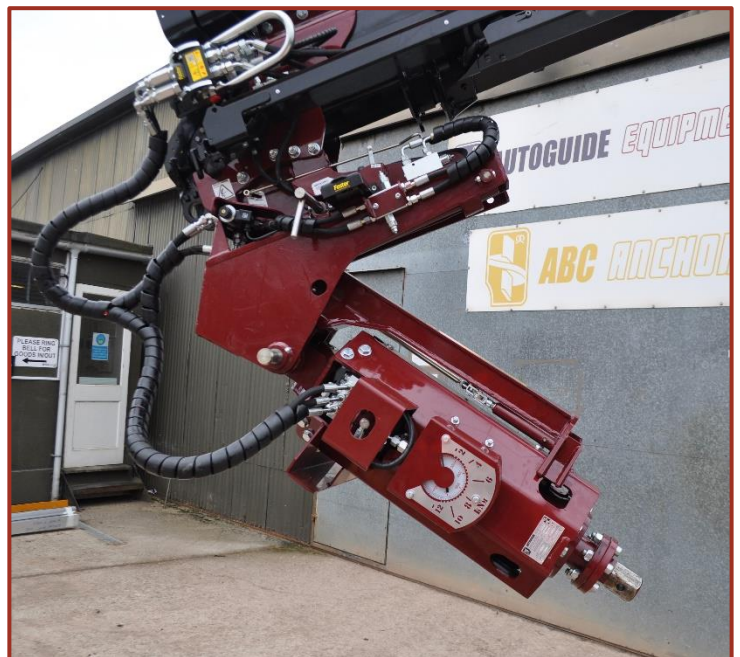

- When the catcher arm is perpendicular to the bracket, the latch will automatically be released and the Powerhead will swing free.

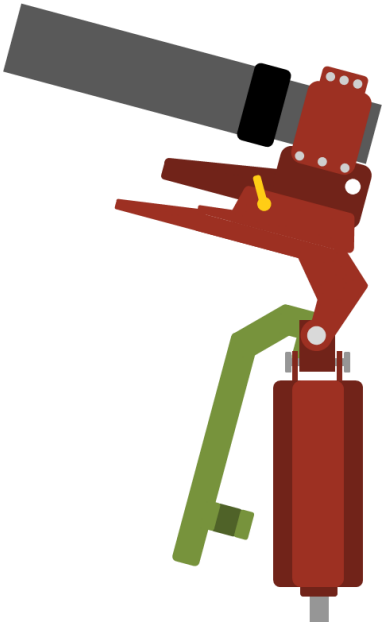

- Raise the catcher arm back into its home position using the hydraulic circuit



- The Powerhead is now ready for use.

Storing the Powerhead

1. Position the crane boom angled away from the ground as shown so that the Powerhead hangs free.

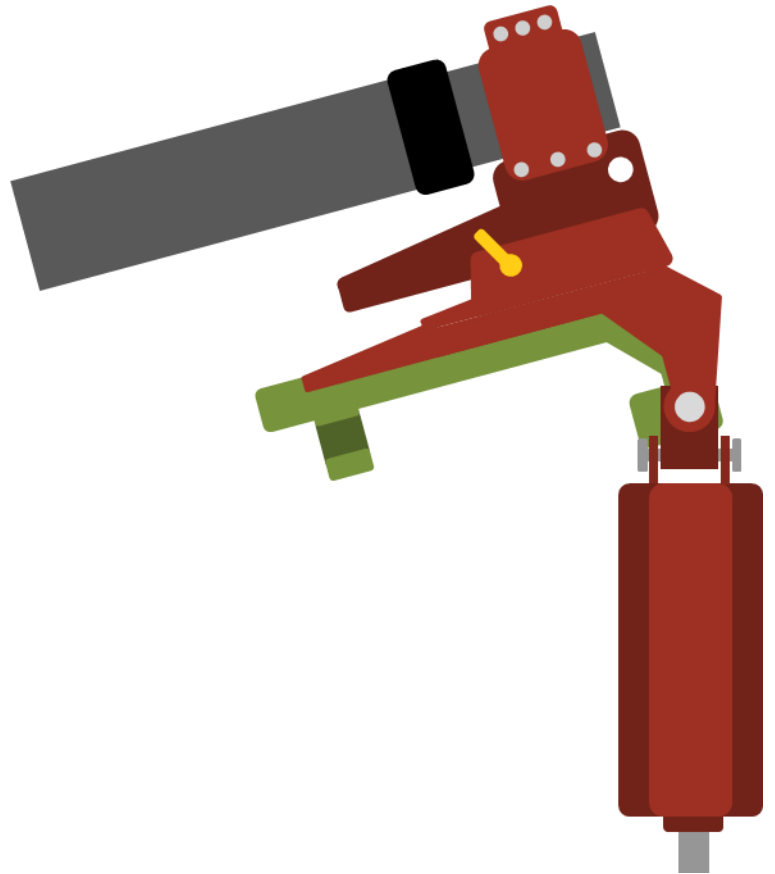

2. Lower the catcher arm and allow it to rotate so that it makes contact with the Powerhead and rotates through 90° from starting position.

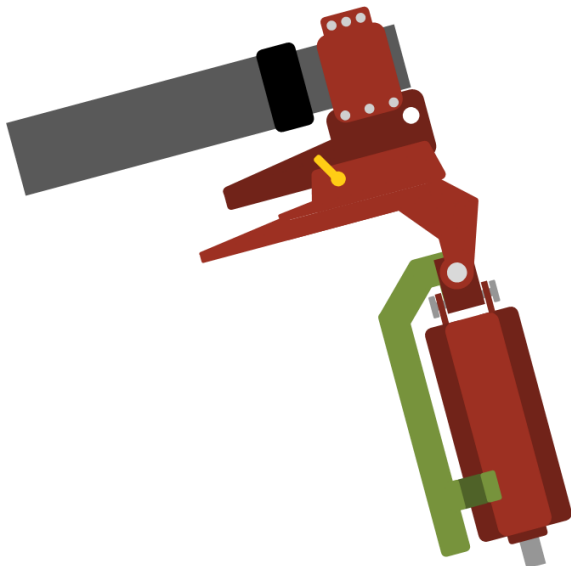

3. When fully rotated the latch pin will automatically extend and pin the Powerhead into the catcher arm. Ensure this has happened by observing the pin position through the

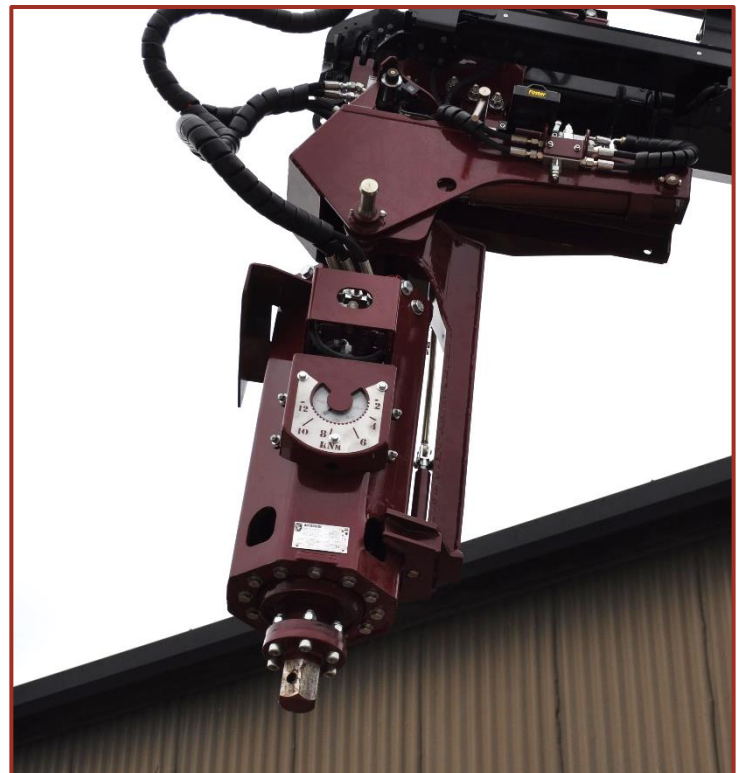

latch plate at the base of the Powerhead, ensuring the pin has gone through all three layers of steel.



4. Once the latch is in place, raise the catcher up back into its home position to stowaway the Powerhead.

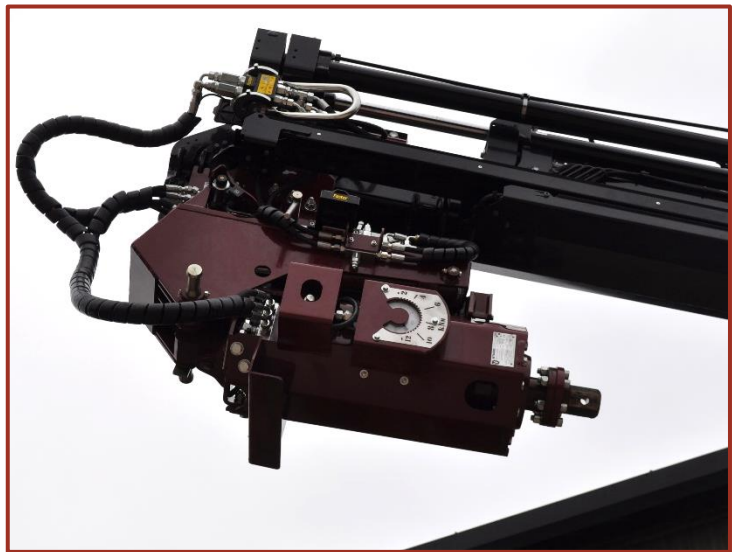

Drilling Holes

1. Attach the Auger to the Powerhead by sliding it over the hexagon bar output.
2. Insert the safety pin through the corresponding holes on both the Auger and Powerhead.
3. Carefully raise the Powerhead on the crane into position with the tip of the auger resting on the ground at the desired hole position.
4. Operate the auxiliary circuit on the crane to start the Powerhead turning.
5. Let the auger penetrate the surface. It may require some additional downwards force depending on the soil classification.
6. Gradually bore out the hole, removing the auger at regular intervals to remove the excess material.

Low Speed Lock

The powerhead is fitted with a Low Speed Lock lever. In standard operation (High) the variable speed motor adjusts its output based on the required torque to auger the hole.

To lock the powerhead into Low Speed mode where the torque is maximised, move the handle located inside the bucket to the “Low” position.

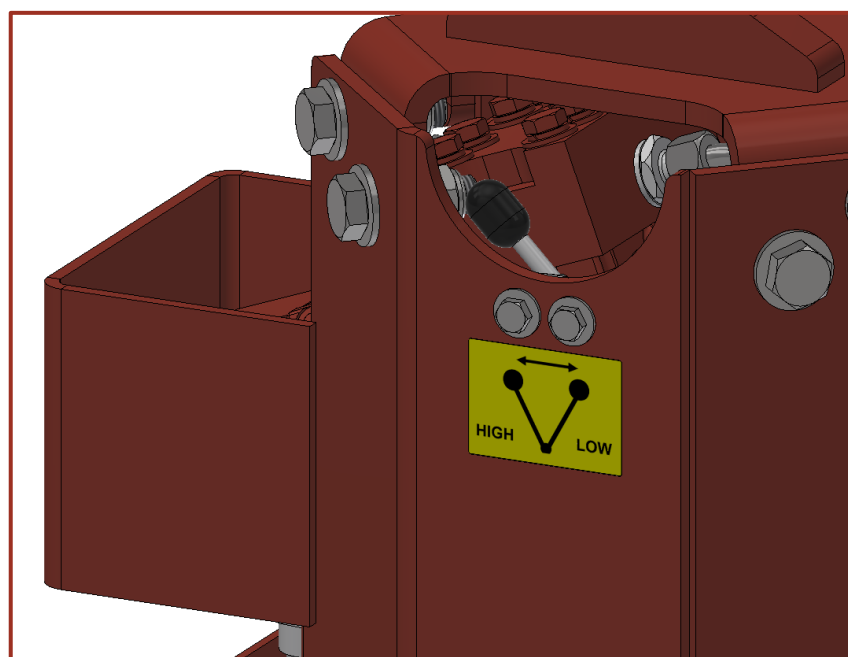

General Principles of Operation

All Powerheads are designed to stall at the rated operating pressures before anything breaks, however continuous operation of stalled motors will overheat the hydraulic system and cause expensive damage. Therefore operate as fast as required but avoid excessive motor stall.

When drilling it is better to remove the auger from the hole when it is half full of soil and remove the excess. If loose material comes beyond the top of the auger it may act as an anchor and prevent the auger from being raised/ In such cases engage reverse to get it out.

Always replace worn teeth before damage occurs to the tooth holders. Regular hard face welding will extend the auger life.

Rock Ripper augers will drill very hard material but the rate of penetration depends on the down force available. The Rockmaster hammer system available from Autoguide permits high penetration rates even with lorry mounted cranes.

In hard material careful addition of water to the powder material in the hole will allow the auger to work at increased rates.

Dismounting the Attachment

1. Move the crane until the attachment is positioned on a suitable bracket or set on solid ground for stability.
 - a. In the case of the pole grab (if fitted) this will usually be carried on a custom bracket so ensure it is firmly clamped in position.
 - b. In the case of an Auger Powerhead this will usually be supported by a suitable bracket which presents the quick hitch.
2. Having parked the attachment safely, disconnect the hydraulic quick coupler.
3. Stow the Hydraulic coupler in the dummy connector provided on the side of the attachment.



4. Next open the locking valve **I** and pressurise the claw operating cylinder (Auger DIG).



5. Remove the safety pin **G** and move the safety latch **F** to the UNLOCK position by pulling handle **J**.

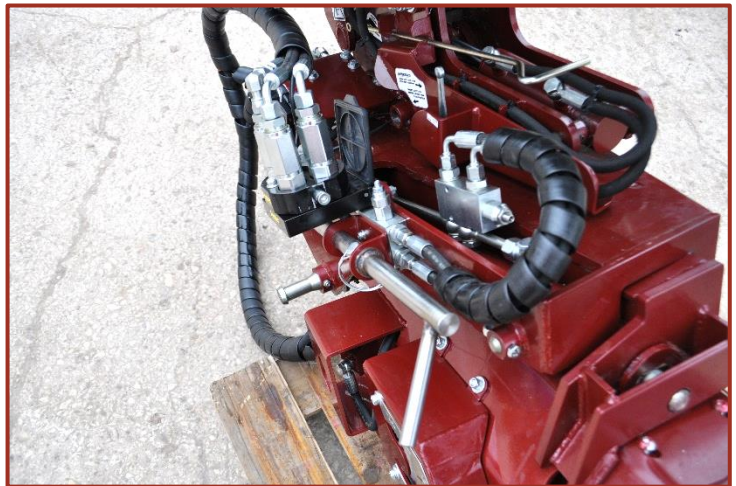

6. Standing clear of the equipment, release the claw by pressurising the ram (Auger REVERSE). Once the claws have retracted, move the crane back and away from the attachment gently.

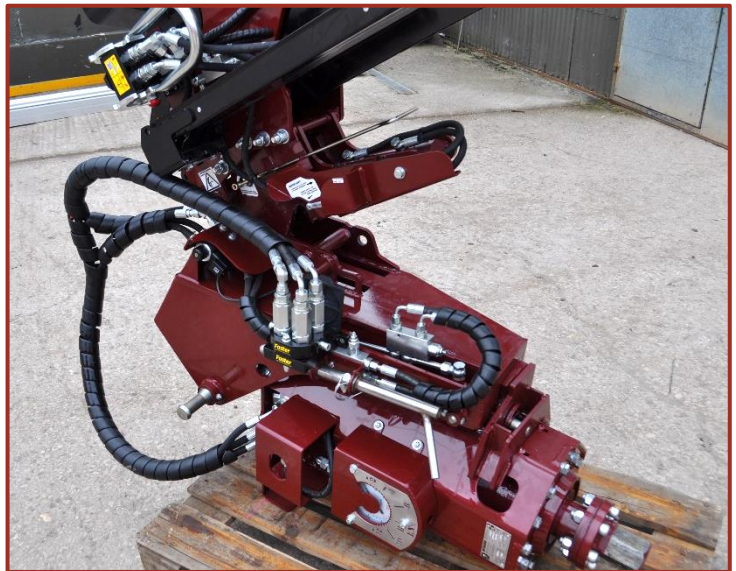

TROUBLESHOOTING

Symptom	Possible Cause	Action
Jerky	Cold Oil	Allow time to warm up
	Air in Pipes	Check oil Level
	Non Compatible Quick Couplers	Use Matched pairs
	Non Compatible Quick Couplers	Replace
	Hoses too small for flow	Replace
	Wrong Model Powerhead	Select appropriate model
Slow	Pump Failing	Carry Out flow and Pressure Check
	Oil Filter Blocked	Carry Out flow and Pressure Check
	Dirt Contamination	Service Exchange Motor
	Low Speed Lock Engaged	Put Selector in Auto
Poor Torque	Low Hydraulic Pressure	Carry Out Flow and Pressure Check
	Excessive Oil Temperature	Check Pump, Check Hose Sizes, Use Correct Powerhead
	Relief Valve Blows	Use smaller Auger or Larger Powerhead
Oil leaks	Loose Fittings	Tighten Up Fittings
	Leaky Connections	Reseal or check Configuration
	Pressure Too High	Use compatible head and fittings
Leak from Relief Valve	Drain Link is Kinked	Check 2 bar max back Pressure. Replace Relief Valve.
	Non Return Valve Seizes	Remove unit and check ball is free moving. Ball can become wedged & sticky, due to high pressure (over 20 bar) or extended storage. Replace valve & relief valve

END OF LIFE

When the machine reaches the end of its useable lifetime it is important that the independent elements of the machine are reused, recycled or disposed of suitably.

Component	What to do?
Metals	All metals should be recycled with an appropriate scrap metal merchant, preferable sorted into metal type.
Electronics	All electrical components should be recycled at an appropriate facility according to the WEEE Directive and Regulations 2013
Oils	Oil waste is classed as Hazardous and therefore must be stored separately and according to legal regulations (that differ dependent on country). It must be disposed of by a suitable Waste Oil collection company.
Hydraulic Hoses	Hydraulic hoses should be drained of oil, metal ends removed and then recycled with a suitable specialist recycling company. Metal ends can be sent to metal recycling centers.
Plastics	All plastics should be sorted into recyclable and non-recyclable and then either sent to suitable recycling facilities or landfill.

SPARE PARTS

27649 – 50,000PXV Auger Power Head

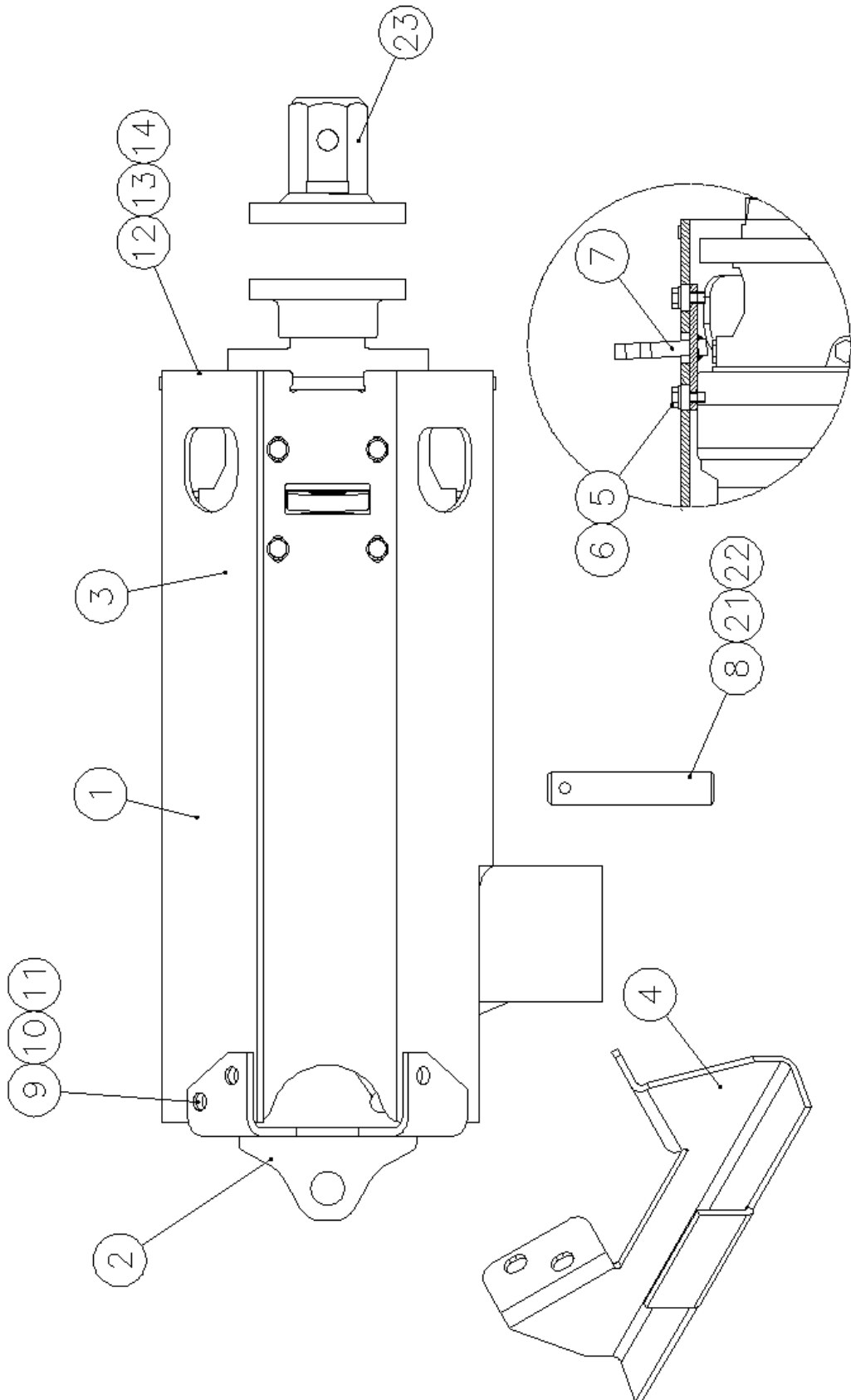

Code
27649

Description
50,000PXV Auger Power Head

No.	Code	Description	Quantity
1	27648	BODY W/A 50,000 PXV	1
2	34637	TOP PLATE W/A	1
3	27671	MOTOR & GEARBOX	1
4	35030	PARKING FOOT 50.000 (2010)	1
5	03807	BOLT M010 X 020 SET	4
6	02702	WASHER M010 FLAT FORM C	4
7	34064	LATCHING EYE W/A	1
8	34638	W/A TOP PIN Ø1 1/4IN	1
9	06000	BOLT M016 X 045	8
10	02104	WASHER M016 FLAT FORM C	16
11	03941	NUT M016 NYLOC P	8
12	02352	BOLT M014 X 055	12
13	03008	WASHER M014 FORM C	24
14	03006	NUT M014 NYLOC	12
20	31867	50.000PXV HYDRAULICS	1
21	01638	PIN COTTER 3/8 X 2	1
22	02137	NIPPLE GREASE M006 X 001 STRAI	1
23	22347	ADAPTER 6 BOLT/M065 MALE	1

41700 – Fold Up Bracket

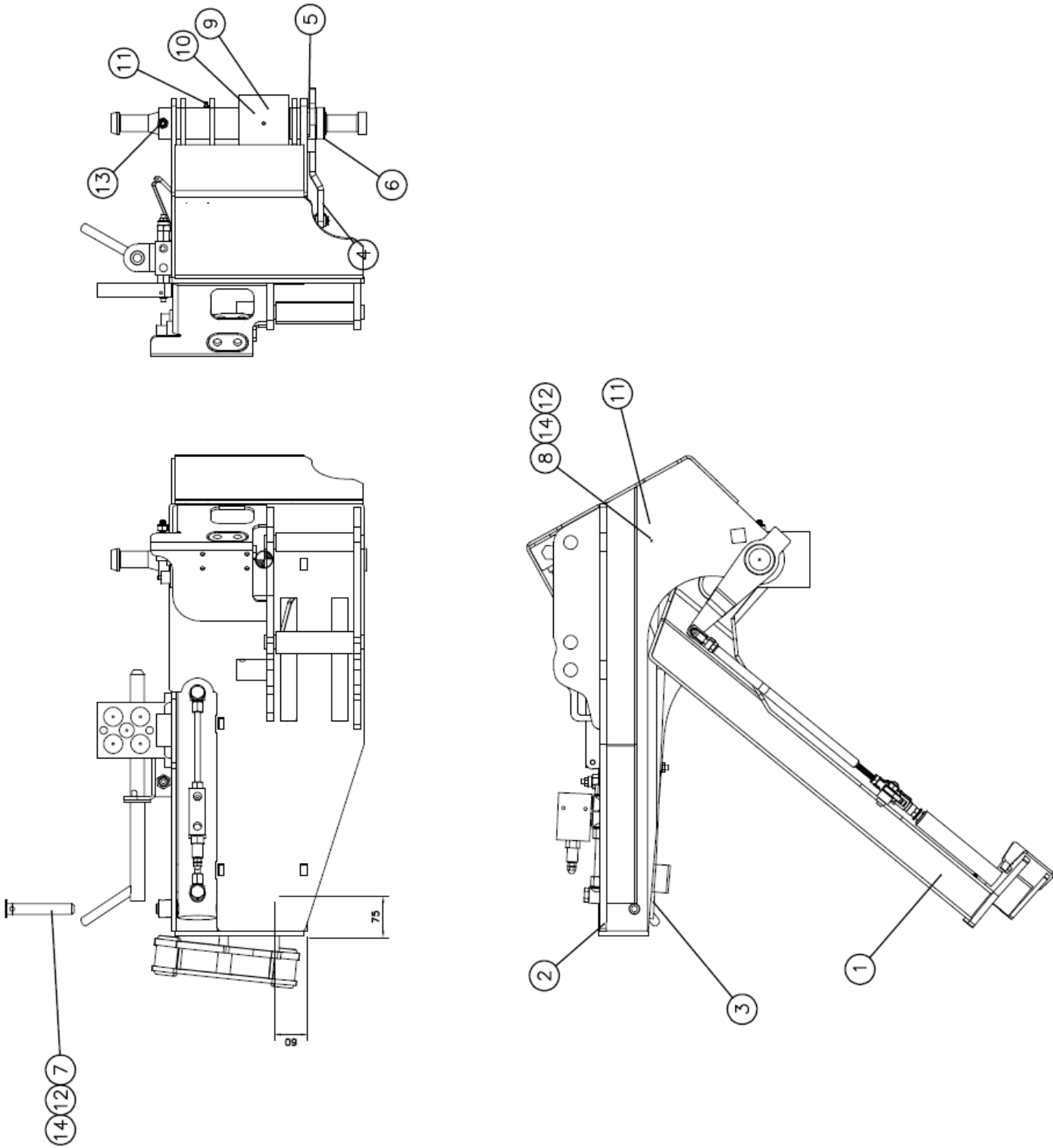

Code
41700

Description
Fold Up Bracket

No.	Code	Description	Quantity
1	42578	CATCHER ARM ASSEMBLY 2018	1
2	40727	RAM MOUNT W/A 2018	1
3	01599	D/A RAM (FOLD-UP BRKT)	1
4	27218	LINK OPERATING ARM	1
5	27268	FLANGED BUSH	1
6	33977	EXTENDED PIVOT SHAFT W/A	1
7	42597	RAM PIN REAR W/A 2018	1
8	27222	RAM PIN FRONT W/A	1
9	27253	W/A SWIVEL BLOCK 65MM	1
10	05924	BUSH IGUS 4044-40 GSM	2
11	02137	GREASE NIPPLE M6 STRAIGHT	3
12	03424	BOLT M008 X 045	2
13	02455	BOLT M008 X 070	1
14	05905	NUT M008 NYLOC THIN TYPE T	3
15	42580	FOLD UP BRACKET HYDRAULICS 2018	1
16	42451	LOCK PIN STOWAGE BRACKET	1
17	30733	W/A LOCKING PIN EXTENDED	1
18	05591	PIN SHAFT LOCKING 57MM X 006	1

34250 – Fold Up Bracket Hydraulics

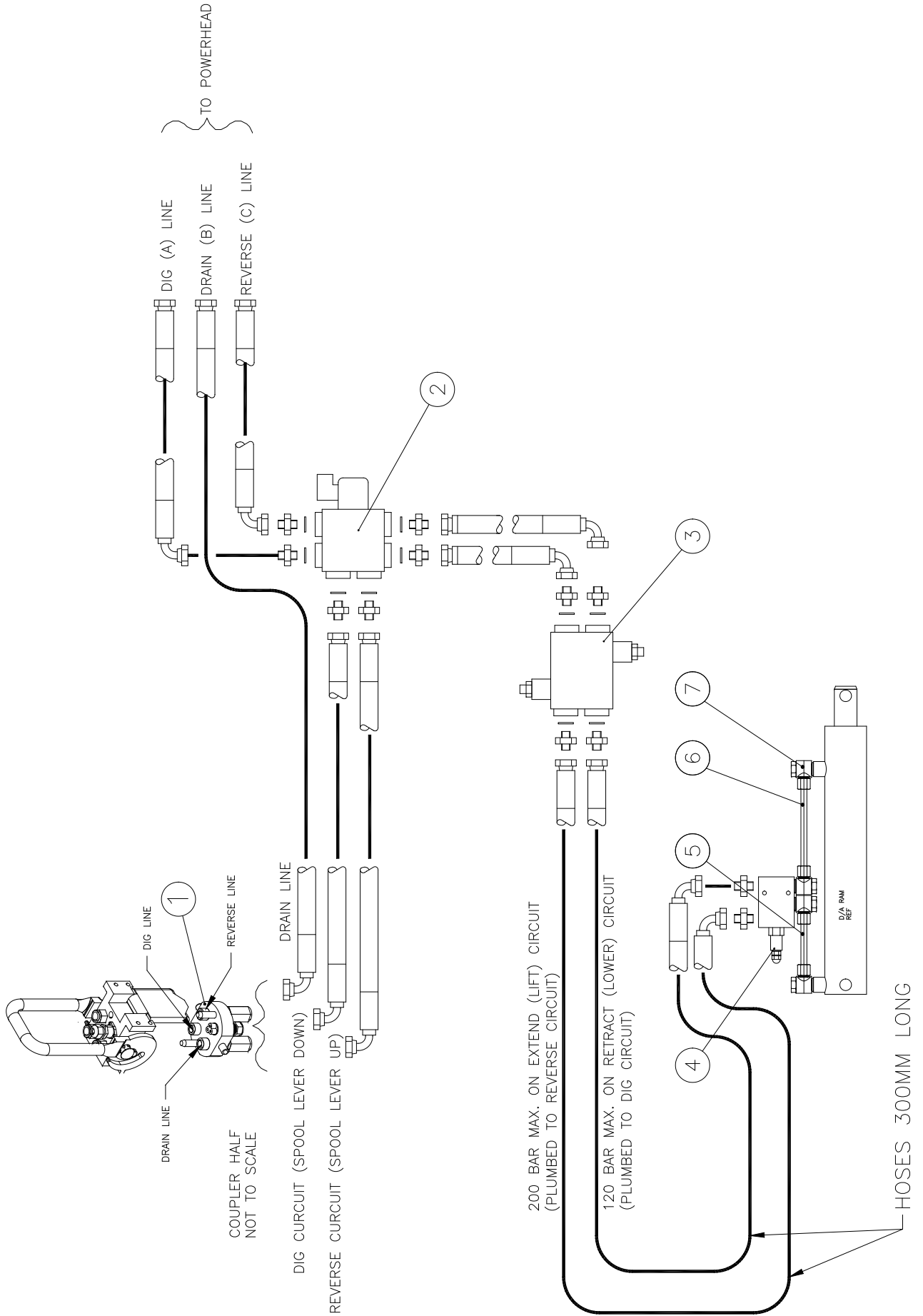

Code
34250

Description
Fold Up Bracket Hydraulics

No.	Code	Description	Quantity
1	3545	'FASTER' QUICK RELEASE COUPLER	1
2	8712	SOLENOID VALVE	1
3	8637	DUAL CROSS LINE RELIEF VALVE	1
4	2735	SINGLE OVERCENTRE VALVE	1
5	34986	10S STEEL HYDRAULIC TUBE 100 LG	1
6	34985	10S STEEL HYDRAULIC TUBE 160 LG	1
7	9857	10S BANJO FITTING	4

34312 – Quick Hitch Assembly

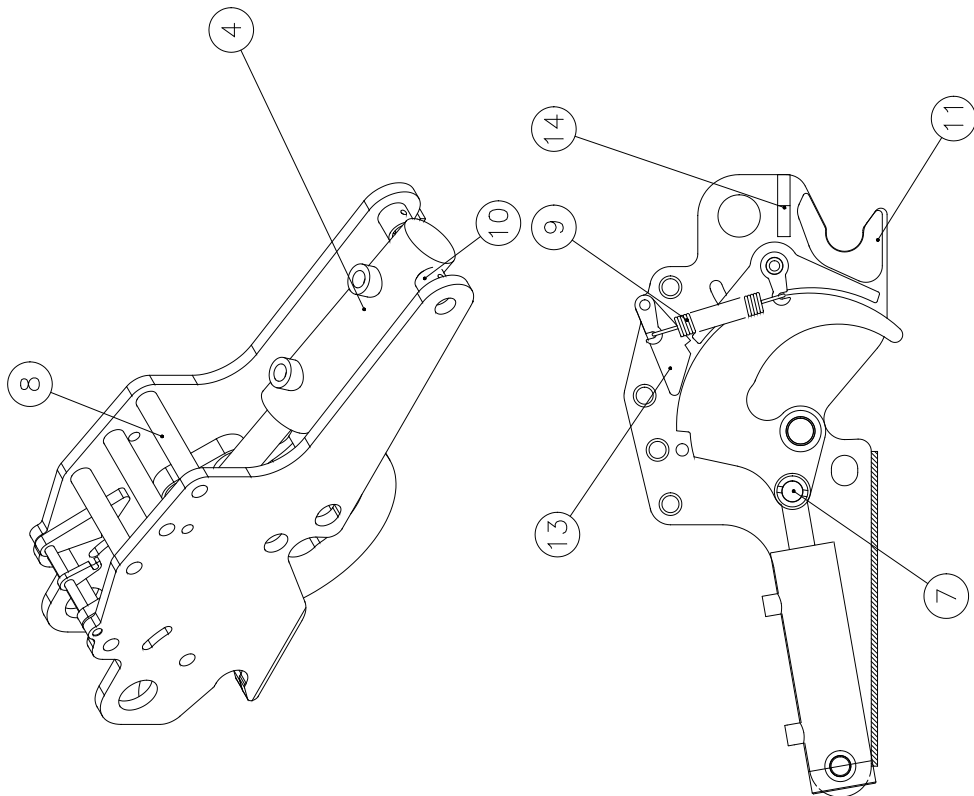
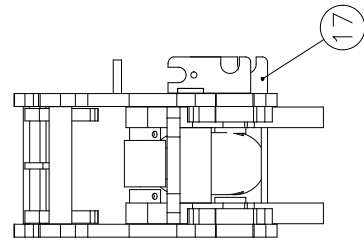
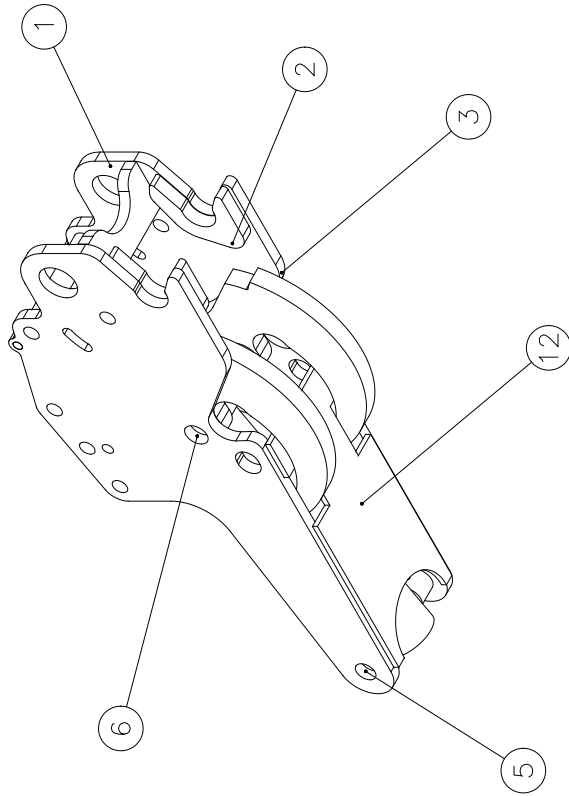

Code
34312

Description
Quick Hitch Assembly

No.	Code	Description	Quantity
1	34301	SIDE PLATE - QUICK HITCH	2
2	34303	PRIMARY LATCH W/A	1
3	34292	CLAW W/A	1
4	34568	D/A RAM MODIFIED (701/1)	1
5	34299	RAM PIN - QUICK HITCH	1
6	34297	CHROME SHAFT Ø25 X 150	1
7	34296	PIVOT PIN Ø20 X 113	1
8	34302	SPACER TUBE 22 X 16.5 X 113	4
9	8777	TENSION SPRING	1
10	34300	BOSS Ø30 X 22.2 X 27	2
11	34315	HOOK REINFORCEMENT	2
12	34339	REINFORCING PLATE	1
13	34304	SECONDARY LATCH W/A	1
14	35050	PLATE 60 X 12 X 113	1
15	1629	VALVE CHECK 004 PO VBD	1
16	RH448	GATE VALVE	1
17	35024	GATE VALVE MOUNT	2
18	35034	DECALS - CEVA QUICK HITCH	1
19	37478	QUICKHITCH GUARD KIT	1

30733 – Quick Hitch Latch Pin

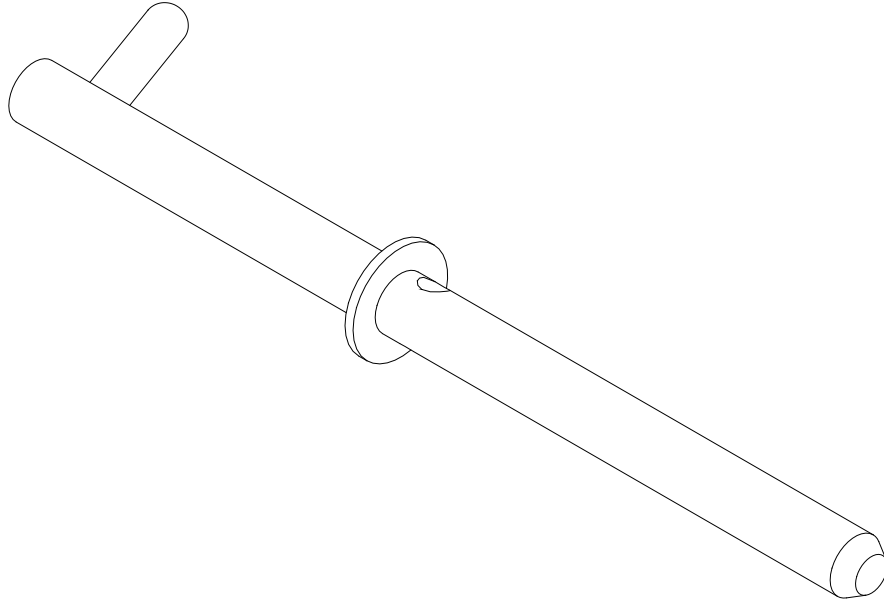

Code	Description
30733	Quick Hitch Latch Pin

No.	Code	Description	Quantity
1	30733	W/A LOCKING PIN EXTENDED	1
2	5591	SHAFT LOCKING PIN 3/8IN X 57	1

Stowage Cradle

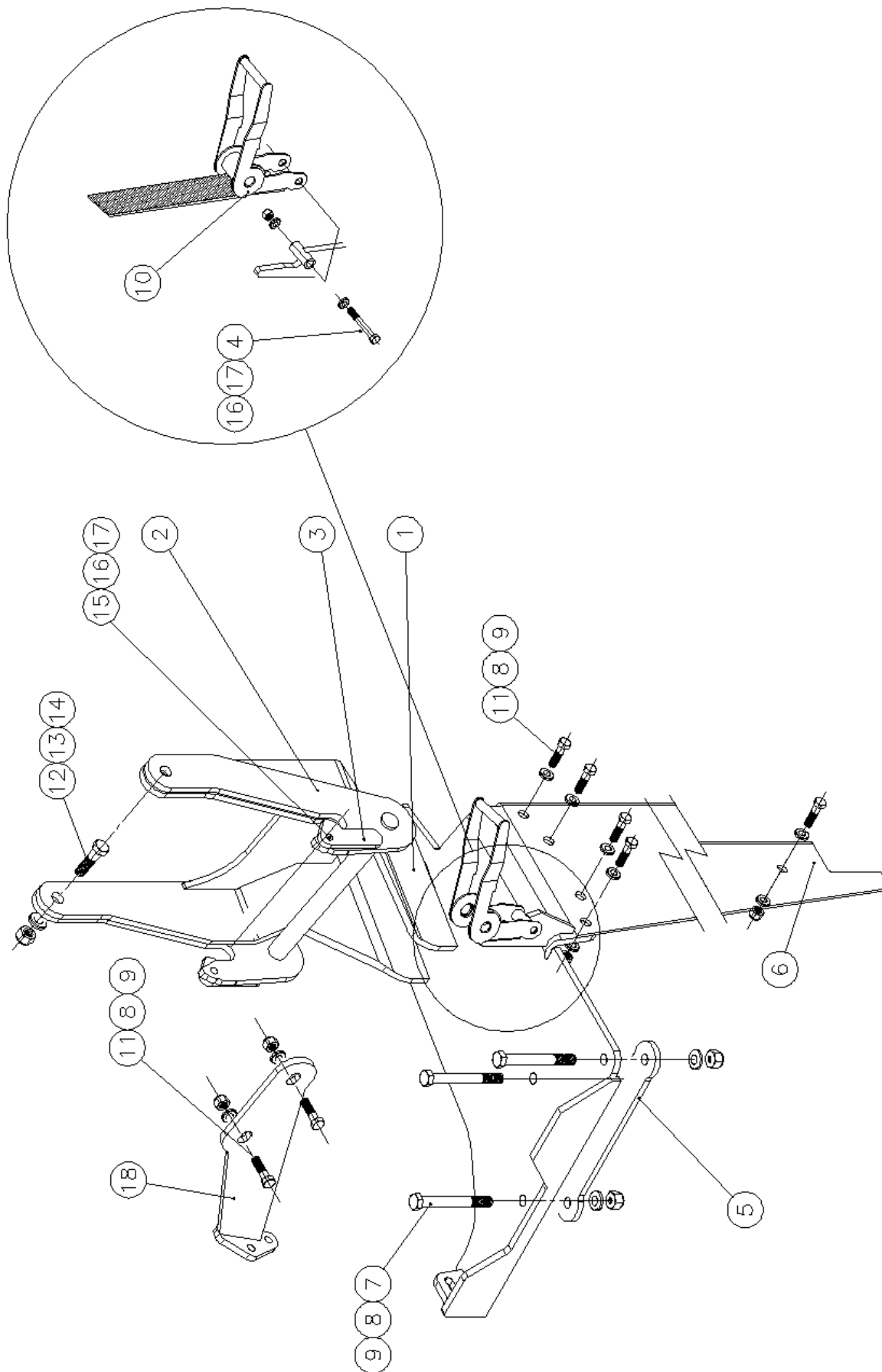

Code
See Page 1

Description
Support Cradle

No.	Code	Description	Quantity
1	*	SUPPORT CRADLE W/A	1
2	35083	HOOK W/A	1
3	33973	GRAVITY LATCH	2
4	02775	BOLT M012 X 080	1
5	35089	CLAMP PLATE	1
6	38562	CRADLE SUPPORT LEG 2014	1
7	02494	BOLT M016 X 100	3
8	02104	WASHER M016 FLAT FORM C	12
9	03941	NUT M016 NYLOC P	8
10	09219	STRAP RATCHET 10M 5 TONNE	1
11	03662	BOLT M016 X 040 SET	5
12	03031	BOLT M020 X 060	2
13	03868	WASHER M020 FLAT FORM C	2
14	02540	NUT M020 NYLOC	2
15	03866	BOLT M012 X 050	2
16	02105	WASHER M012 FLAT FORM C	6
17	02774	NUT M012 NYLOC	3
19	30061	SHIM - 250 A/F POWERHEAD 1.0T	2
20	30701	GAUGE BOX W/A	1
21	30200	GAUGE SCALE 0-6 STAINLESS	1
22	8635	GAUGE 0-400 BAR 6IN BOTT ENT	1

** Code dependant on Top Level Part number. Contact Autoguide for advice on part code.*

Stowage Frame

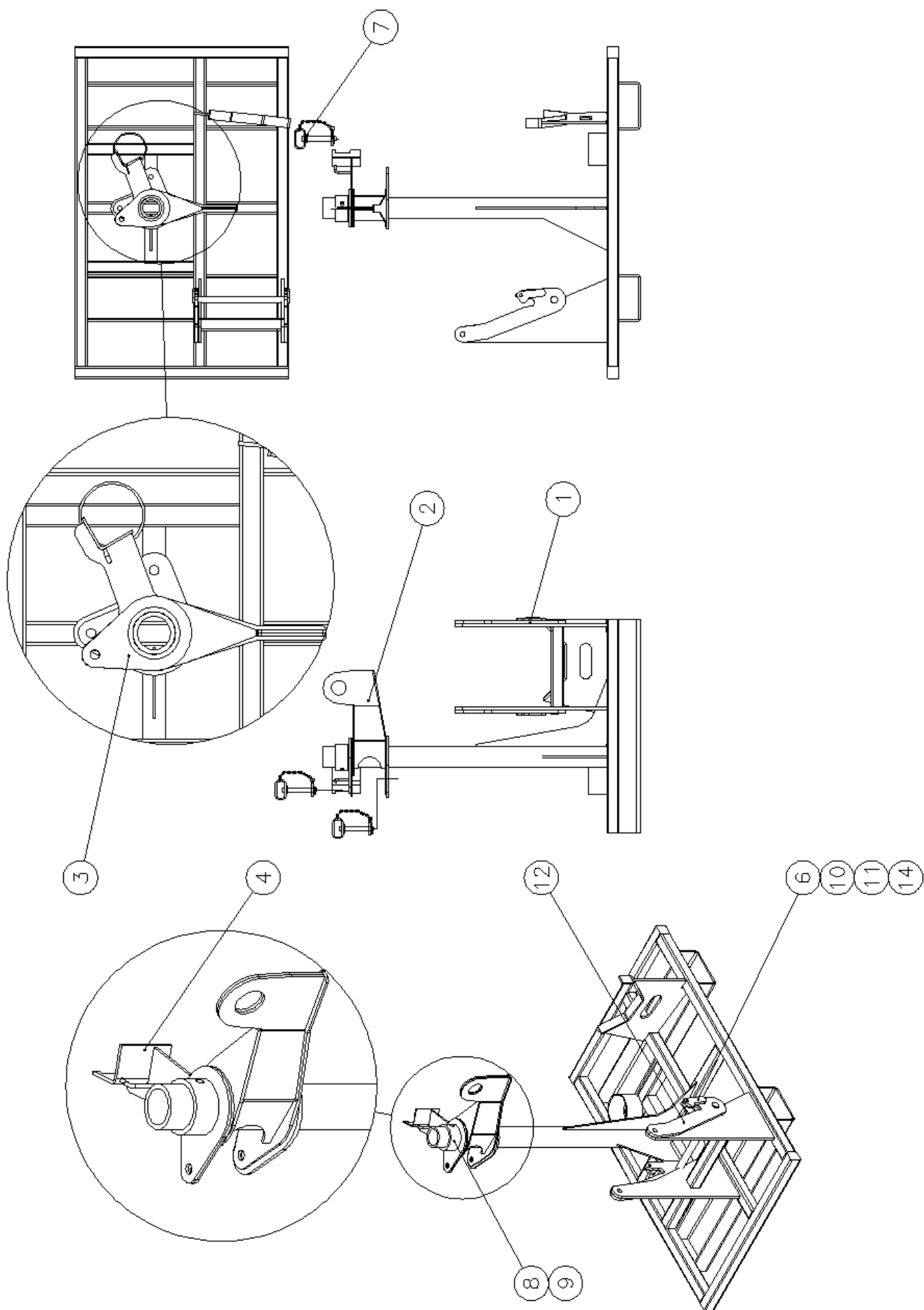

Code
See Page 1

Description
Stowage Frame

No.	Code	Description	Quantity
1	*	STOWAGE FRAME W/A	1
2	33866	LIFTING ARM - S&S	1
3	33812	BOSS W/A	1
4	40278	AUGER SUPPORT ARM ASSY	1
14	2774	NUT M012 NYLOC	2
6	33973	GRAVITY LATCH	2
7	9528	PIN M19 X 98L C/W LINCH PIN	3
8	4187	BOLT M016 X 120	1
9	3941	NUT M016 NYLOC P	1
10	3866	BOLT M012 X 050	2
11	2105	WASHER M012 FLAT FORM C	6
12	35083	HOOK W/A	1
13	1207	BOLT M012 X 060	2

** Code dependant on Top Level Part number. Contact Autoguide for advice on part code.*



Autoguide Equipment
Stockley Road
Heddington
Nr. Calne
Wiltshire SN11 0PS
England
Tel: +44 (0) 1380 850885
Website: www.autoguide.co.uk

