



AUTOGUIDE EQUIPMENT



EXCAVATOR MOUNTED POWERHEADS

F RANGE



MANUAL SPARE PARTS

Autoguide Equipment Ltd
Stockley Road,
Heddington, Calne,
Wiltshire, UK,
SN11 0PS
+44(0)1380 850885
www.autoguide.co.uk

Published: 15 March 2023
ID: M025 1.2

These instructions give safety and operations information regarding the use of a Excavator Mounted Auger Powerhead supplied by Autoguide Equipment. They contain the relevant information for products:

Product Code	Description	Maximum Output Power (Nm)
34084	90F Powerhead	10,000
34092	160F Powerhead	20,000

To ensure optimum results when operating this equipment it is very important to read this manual carefully, the information will prepare you to do a better, safer job.

Before operating the machine you should familiarise yourself with the instructions in this manual. Incorrect use can lead to damage which is not covered by the Warranty Conditions. This may create a dangerous situation or lead to unsatisfactory results.

These operating instructions **MUST** always be made available to the person or persons operating this equipment.

To assist in the ordering of spares, or other communications with our company, the serial number of the relevant equipment supplied, has been recorded below for your information.

Model No:-

Serial No:-

Date of Delivery:-

CONTENTS

- Information3
 - Safety Instructions3
 - Daily Check Items.....3
 - Powerhead Compatibility4
 - Powerhead Model4
 - Compatibility.....4
 - Hole Size.....4
 - Soil Type4
 - Auger Selection5
 - Aggressor Augers6
 - Heavy Duty Augers6
 - Rock Ripper Augers6
- Powerhead Installation8
 - Attaching the Powerhead to the Power Unit8
 - Pre-operation check list9
- Auger Operation10
 - Drilling Holes10
 - General Principles of Operation.....10
- Troubleshooting11
- End of Life12
- Spare Parts List.....13
 - 34084 - 90F Auger Powerhead.....13
 - 34092 - 160F Auger Powerhead.....15

INFORMATION

Your Powerhead has been individually built with great emphasis on quality, strength and simplicity of design and with routine care will give many years of trouble free operation.

The following instructions have been written to cover the use and maintenance of the machine. Care should be taken to ensure that you are referring to the correct section of your machine before carrying out any adjustments, or when ordering spare parts.

Like all mechanical products, regular cleaning, lubrication and maintenance will ensure a longer trouble free life. These instructions make no attempt to go beyond routine maintenance, and it is strongly advised that you contact your dealer should any major repairs become necessary.

Use only genuine service parts; non genuine parts may not meet standards required for safe and satisfactory operation.

Observe all safety information in the manual and on decals fitted to the machine and power unit.

Safety Instructions

1. Read and understand this operator's manual prior to operating the machine and keep it in a convenient place for future reference.
2. Keep untrained personnel away from the machine whilst it is in operation.
3. Keep all guards and safety devices in place.
4. Do not operate machine with guards removed.
5. Beware, pressured hydraulic oil can be very dangerous and can penetrate the skin - TAKE THE UTMOST CARE.
6. Keep hands, feet and loose clothing away from moving parts.
7. Always switch off the machine before making any adjustments or when carrying out lubrication and servicing.
8. Keep all nuts, bolts and fasteners tightened.
9. Check machine regularly for damaged or worn parts.
10. If the machine is left unattended ensure that it is locked or disabled to prevent use by untrained personnel.



Daily Check Items

1. Check the unit is properly and securely attached to the crane/excavator unit.
2. Check that all nuts and bolts are secure, mounting pins are properly retained, and all safety shields are in place. (All nuts and bolts should be checked after the first 10 hours of operation.)

3. Check the condition and security of any auger or anchor driver attachment.
4. Lubricate all grease nipples.

Powerhead Compatibility

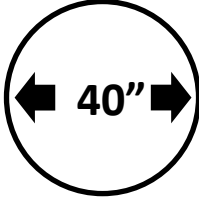
Ensuring that you have the correct Powerhead for both the machine and required hole is important to get the best results and prevent damage to both digger and Powerhead.

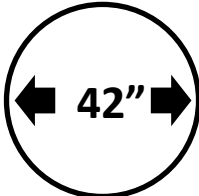
Powerhead Model	Compatibility	Hole Size	Soil Type
90F	 Excavators up to 10t		Soil/Clay/Rock
160F	 Excavators 15t+		Soil/Clay/Rock

Auger Selection

When digging a hole it is important to know what soil type it is that the auger will be trying to penetrate. With this information the correct auger can be selected to give increased penetration and speed.

Soils are classified into 9 categories ranging from hard rock to loose silt. To determine which category will be being augured, a soil probe kit is available from Autoguide Equipment.

Class	Common Soil Type	Geological Soil Classification	Probe Values <i>in/labs (Nm)</i>	Typical Blow Count <i>in/labs (Nm)</i>
1	Sound, hard rock – Unweathered	Granite, Basalt, Massive Limestone	N/A	N/A
2	Very dense and/or cemented sands, Coarse gravel & Cobbles	Caliche (Nitrate-bearing Gravel/Rock)	750-1600 <i>(85-181)</i>	60-100+
3	Dense, Fine Sands, very hard silts & clays (may be pre-loaded)	Basalt Till, Boulder Clay, Caliche, Weathered Laminated Rock	750-1600 <i>(85-181)</i>	45-60
4	Dense sands & gravel, hard silts & clays	Glacial Till, Weathered Shale's, Schist, Gneiss & Sandstone	600-750 <i>(68-85)</i>	35-50
5	Medium dense sand & gravel; very stiff to hard silts and clays	Glacial Till, Hardpan, Marls	500-600 <i>(58-68)</i>	24-40
6	Medium dense coarse sands & sandy gravels; stiff to very stiff clays	Saprolite's, Residual Soils	400-500 <i>(45-56)</i>	14-25
7	Loose to medium dense fine to coarse sands to stiff clays and silt	Dense Hydraulic Fill, Compacted Fill, Residual Soils	300-400 <i>(34-45)</i>	7-14
8	Loose, fine sands; alluvium; loess; medium & varied clays, fill	Flood Plain Soils, Lake Clays, Abode, Fill	100-200 <i>(11-25)</i>	4-8
9	Peat, organic silts, inundated silts, fly ash, very loose sands, very soft	Miscellaneous Fill, Swamp Marsh	Less than 100	0-5

Once the soil classification is known the appropriate auger can be selected.

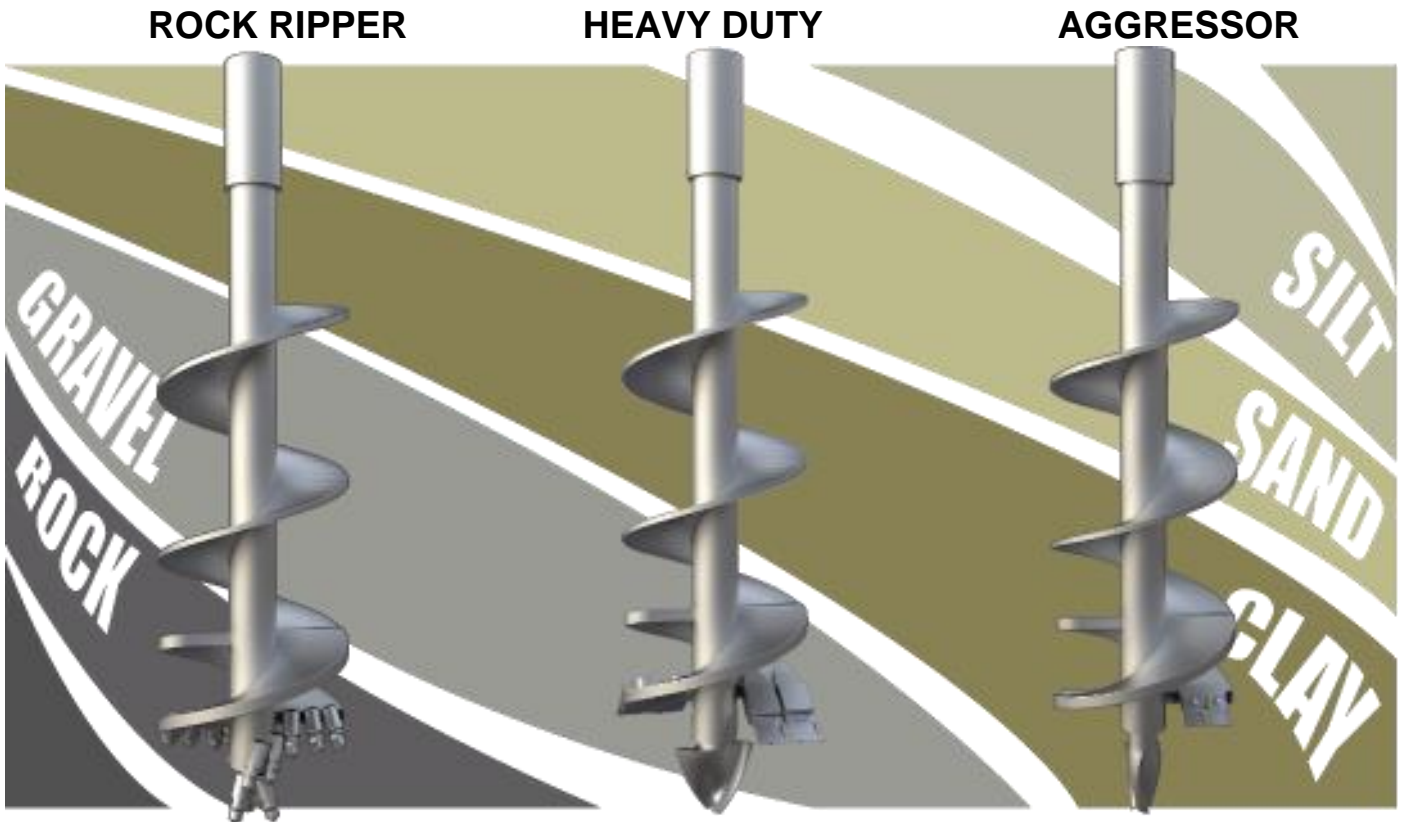

Aggressor Augers

Designed for drilling in loose soil and sand, Aggressor Augers come in 1.2m lengths, with an optional 1m extension.

These suit Powerheads with up to a maximum rated output of 4500Nm. They use a 2" hexagon socket industry standard drive. Standard teeth are bolt on drop forged high carbon steel and carbide versions are available.

Heavy Duty Augers

Designed for drilling in dense gravel and soil, Heavy Duty Augers come in 1.2m lengths, with an optional 1m extension

These suit Powerheads with up to a maximum rated output of 15,000Nm. They use a 2" hexagon or 65mm hexagon drive. Teeth are drop forged special steel or carbide tipped, retained with a rubber lock system.

Rock Ripper Augers

Designed for drilling solid rock, Rock Ripper Augers come in 1.2m lengths, with an optional 1m extension

These feature a unique computer generated tooth layout utilising self-sharpening carbide teeth which rotates in work. Whilst they do not perform well in hard clay soils, they will drill all materials up to hard concrete. Drilling performance in hard conditions depends on the application of sufficient down force. If additional down force is require a Rockmaster hammer system is available from Autoguide.

Autoguide have a wide range of different Augers available to dig holes ranging from 6" to 36" diameter in all soil classifications. These can be both rented and purchased.

POWERHEAD INSTALLATION

The safe operation of this equipment is the responsibility of the operator, who should be familiar with the lifting process, the power unit and all safety practices before starting operations.

Attaching the Powerhead to the Power Unit

1. **SWITCH OFF** the power unit.
2. Lubricate the mounting pins.
3. Attach the Powerhead to the digger using the correct swivel or mounting bracket. Depending on the specification of the Powerhead, ensure that it is mounted facing the correct way to ensure correct hose routing.



4. De-pressurise hydraulic systems using the manufacturers approved techniques before connecting the Powerhead.
5. Ensure all connections are clean and free from dirt before connecting the Powerhead hydraulic supply into the power units' auxiliary hydraulic supply.
6. Connect the hydraulic lines as follows:
 - Port A is connected to flow in.
 - Port B is connected to the flow return.

Note: Hose size and condition of any quick couplers that are used will have an effect on the efficient operation of the unit.

7. Disconnect the hoses from the motor, connect together and flush the system through for a minimum of 10 minutes to ensure any debris from installation is removed by the filter system of the supply.

Note: All hydraulic motors are sensitive to foreign objects in the hydraulic oil. Debris can cause damage thus reducing the efficiency and output power of the motor.

8. Reconnect to the motor, ensuring no debris gets on the connections.
9. Operate the digger's auxiliary circuit to test the Powerhead and ensure rotation.
10. Raise and lower the digger boom to make sure that there is no interference with the boom or swivel bracket.
11. Once complete, lower the auger unit to the ground while not in use.

Pre-operation check list

1. Keep bystanders away from all rotating attachments.
2. Ensure you are aware of the environment you are working in; be aware of overhead cabling and other utilities services.

AUGER OPERATION

Drilling Holes

1. Attach the Auger to the Powerhead by sliding it over the hexagon bar output.
2. Insert the safety pin through the corresponding holes on both the Auger and Powerhead.
3. Carefully raise the Powerhead on the digger boom into position with the tip of the auger resting on the ground at the desired hole position.
4. Operate the auxiliary circuit on the digger to start the Powerhead turning.
5. Let the auger penetrate the surface. It may require some additional downwards force depending on the soil classification.
6. Gradually bore out the hole, removing the auger at regular intervals to remove the excess material.

General Principles of Operation

All Powerheads are designed to stall at the rated operating pressures before anything breaks, however continuous operation of stalled motors will overheat the hydraulic system and cause expensive damage. Therefore operate as fast as required but avoid excessive motor stall.

When drilling it is better to remove the auger from the hole when it is half full of soil and remove the excess. If loose material comes beyond the top of the auger it may act as an anchor and prevent the auger from being raised/ In such cases engage reverse to get it out.

Always replace worn teeth before damage occurs to the tooth holders. Regular hard face welding will extend the auger life.

Rock Ripper augers will drill very hard material but the rate of penetration depends on the down force available. The Rockmaster hammer system available from Autoguide permits high penetration rates even with lorry mounted cranes.

In hard material careful addition of water to the powder material in the hole will allow the auger to work at increased rates.

TROUBLESHOOTING

Symptom	Possible Cause	Action
Jerky	Cold Oil	Allow time to warm up
	Air in Pipes	Check oil Level
	Non Compatible Quick Couplers	Use Matched pairs
	Non Compatible Quick Couplers	Replace
	Hoses too small for flow	Replace
	Wrong Model Powerhead	Select appropriate model
Slow	Pump Failing	Carry Out flow and Pressure Check
	Oil Filter Blocked	Carry Out flow and Pressure Check
	Dirt Contamination	Service Exchange Motor
	Low Speed Lock Engaged	Put Selector in Auto
Poor Torque	Low Hydraulic Pressure	Carry Out Flow and Pressure Check
	Excessive Oil Temperature	Check Pump, Check Hose Sizes, Use Correct Powerhead
	Relief Valve Blows	Use smaller Auger or Larger Powerhead
Oil leaks	Loose Fittings	Tighten Up Fittings
	Leaky Connections	Reseal or check Configuration
	Pressure Too High	Use compatible head and fittings
Leak from Relief Valve	Drain Link is Kinked	Check 2 bar max back Pressure. Replace Relief Valve.
	Non Return Valve Seizes	Remove unit and check ball is free moving. Ball can become wedged & sticky, due to high pressure (over 20 bar) or extended storage. Replace valve & relief valve

END OF LIFE

When the machine reaches the end of its useable lifetime it is important that the independent elements of the machine are reused, recycled or disposed of suitably.

Component	What to do?
Metals	All metals should be recycled with an appropriate scrap metal merchant, preferable sorted into metal type.
Electronics	All electrical components should be recycled at an appropriate facility according to the WEEE Directive and Regulations 2013
Oils	Oil waste is classed as Hazardous and therefore must be stored separately and according to legal regulations (that differ dependent on country). It must be disposed of by a suitable Waste Oil collection company.
Hydraulic Hoses	Hydraulic hoses should be drained of oil, metal ends removed and then recycled with a suitable specialist recycling company. Metal ends can be sent to metal recycling centers.
Plastics	All plastics should be sorted into recyclable and non-recyclable and then either sent to suitable recycling facilities or landfill.

SPARE PARTS LIST

34084 - 90F Auger Powerhead

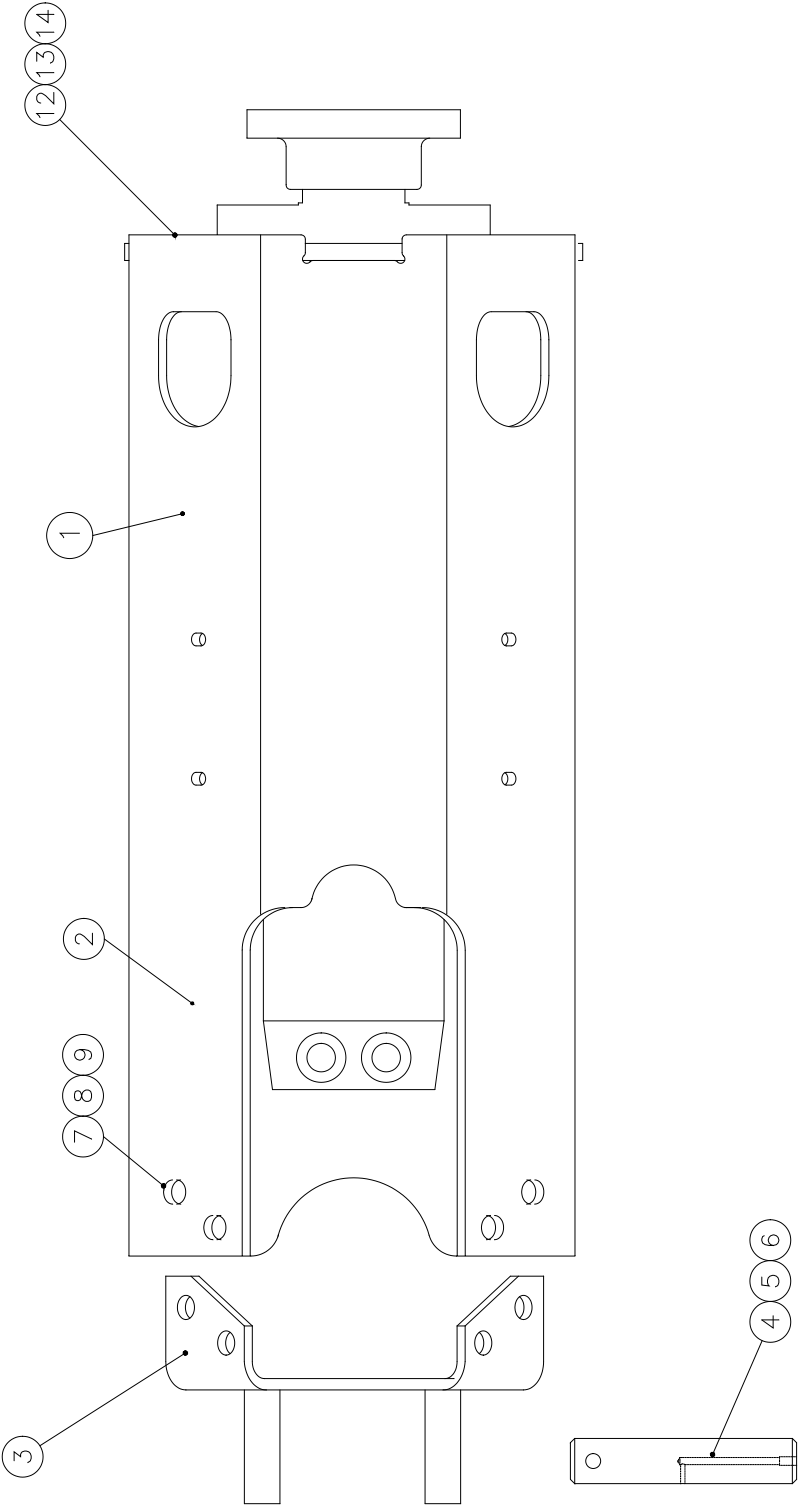

Code
34084

Description
90F Auger Powerhead

No.	Code	Description	Quantity
1	34083	MOTOR & GEARBOX	1
2	27648	BODY W/A	1
3	34637	TOP PLATE W/A	1
4	34638	W/A TOP PIN %%C1 1/4IN	1
6	2137	NIPPLE GREASE M006 X 001 STRAIT	1
7	6000	BOLT M016 X 045	8
8	2104	WASHER M016 FLAT FORM C	22
9	3941	NUT M016 NYLOC P	14
10	2352	BOLT M014 X 055	12
11	3008	WASHER M014 FORM C	12
12	3006	NUT M014 NYLOC	12
13	3867	BOLT M16 X 65	6
14	22347	ADAPTOR 6 BOLT/65 HEX	1

34092 - 160F Auger Powerhead

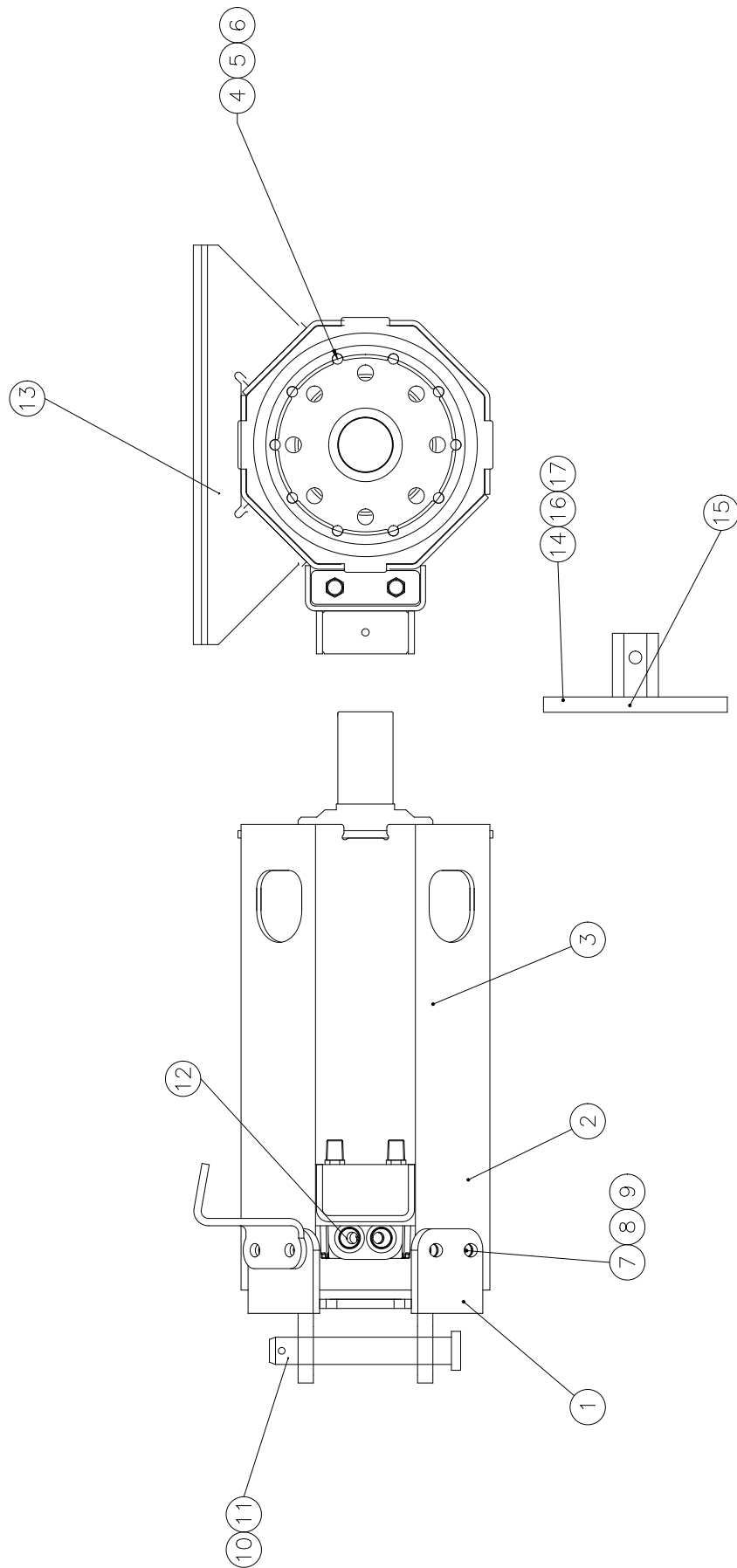

Code
34092

Description
160F Auger Power Head

No.	Code	Description	Quantity
1	28705	TOP PLATE W/A - 90.000PX	1
2	28700	90.000PX BODY W/A 760LG	1
3	34085	GEARBOX ASSY 160F	1
4	2363	M16X50 HEX HD SETSCREW	10
5	2104	M16 PLAIN WASHER FORM C	10
6	3941	M16 NYLOC NUT	10
7	3721	M20X45 HEX HD SETSCREW	8
8	3868	M20 PLAIN WASHER FORM C	16
9	2540	M20 NUT NYLOC	8
10	29216	TOP SWIVEL PIN W/A	1
11	4117	SPLIT PIN	1
12	5997	1 5/16IN X 3/4IN MM JIC BSP	2
13	28757	BOLT ON FOOT-90.000PX	1
14	8895	BOLT M024 X 100	8
15	30992	ADAPTOR 8 BOLT/65 HEX	1
16	8022	M024 NYLOC NUT	8
17	8298	M024 PLAIN WASHER	16



Autoguide Equipment
Stockley Road
Heddington
Nr. Calne
Wiltshire SN11 0PS
England
Tel: +44 (0) 1380 850885
Website: www.autoguide.co.uk

