



AUTOGUIDE EQUIPMENT



40,000PXV ROPE WIND UP BRACKET

MANUAL SPARE PARTS

Autoguide Equipment Ltd
Stockley Road,
Heddington, Calne,
Wiltshire, UK,
SN11 0PS
+44(0)1380 850885
www.autoguide.co.uk



Published: 16 March 2023
ID: M023 1.7

These instructions give safety and operations information regarding the use of a Crane Mounted Rope Wind up Bracket and Auger Powerhead supplied by Autoguide Equipment. They contain the relevant information for products:

Product Code	Description	Maximum Output Power (Nm)
47251	40,000PXV Powerhead	10,000
48414	Rope Wind Up Bracket	-

To ensure optimum results when operating this equipment it is very important to read this manual carefully, the information will prepare you to do a better, safer job.

Before operating the machine you should familiarise yourself with the instructions in this manual. Incorrect use can lead to damage which is not covered by the Warranty Conditions. This may create a dangerous situation or lead to unsatisfactory results.

These operating instructions **MUST** always be made available to the person or persons operating this equipment.

To assist in the ordering of spares, or other communications with our company, the serial number of the relevant equipment supplied, has been recorded below for your information.

Model No:-

Serial No:-

Date of Delivery:-

CONTENTS

Information	4
Safety Instructions	4
Daily Check Items.....	4
Auger Selection	5
Aggressor Augers	6
Heavy Duty Augers	6
Rock Ripper Augers	6
Powerhead Installation	8
Preparing the Powerhead	8
Pre-operation check list	8
Powerhead Operation	9
Operating the Rope Wind-Up Bracket	9
Releasing the Powerhead	9
Drilling Holes	12
General Principles of Operation.....	12
Storing the Powerhead	13
Maintenance Schedule.....	16
Daily.....	16
Weekly.....	16
Monthly	16
Annually.....	17
Troubleshooting	18
End of Life	19
Spare Parts	20
Wind-Up Bracket.....	20
Rope Wind Up Assembly 1	22
Rope Wind Up Hydraulics.....	24
Powerhead	26

INFORMATION

Your Powerhead has been individually built with great emphasis on quality, strength and simplicity of design and with routine care will give many years of trouble free operation.

The following instructions have been written to cover the use and maintenance of the machine. Care should be taken to ensure that you are referring to the correct section of your machine before carrying out any adjustments, or when ordering spare parts.

Like all mechanical products, regular cleaning, lubrication and maintenance will ensure a longer trouble free life. These instructions make no attempt to go beyond routine maintenance, and it is strongly advised that you contact your dealer should any major repairs become necessary.

Use only genuine service parts; non genuine parts may not meet standards required for safe and satisfactory operation.

Safety Instructions

1. Read and understand this operator's manual prior to operating the machine and keep it in a convenient place for future reference.
2. Keep untrained personnel away from the machine whilst it is in operation.
3. Keep all guards and safety devices in place.
4. Do not operate machine with guards removed.
5. Beware, pressured hydraulic oil can be very dangerous and can penetrate the skin
- TAKE THE UTMOST CARE.
6. Keep hands, feet and loose clothing away from moving parts.
7. Always switch off the machine before making any adjustments or when carrying out lubrication and servicing.
8. Keep all nuts, bolts and fasteners tightened.
9. Check machine regularly for damaged or worn parts.
10. If the machine is left unattended ensure that it is locked or disabled to prevent use by untrained personnel.

Daily Check Items

1. Check the unit is properly and securely attached to the crane/excavator unit.
2. Check that all nuts and bolts are secure, mounting pins are properly retained, and all safety shields are in place. (All nuts and bolts should be checked after the first 10 hours of operation.)
3. Check the condition and security of any auger or anchor driver attachment.
4. Lubricate all grease nipples.

Auger Selection

When digging a hole it is important to know what soil type it is that the auger will be trying to penetrate. With this information the correct auger can be selected to give increased penetration and speed.

Soils are classified into 9 categories ranging from hard rock to loose silt. To determine which category will be augured, a soil probe kit is available from Autoguide Equipment.

Class	Common Soil Type	Geological Soil Classification	Probe Values <i>in/labs (Nm)</i>	Typical Blow Count <i>in/labs (Nm)</i>
1	Sound, hard rock – Unweathered	Granite, Basalt, Massive Limestone	N/A	N/A
2	Very dense and/or cemented sands, Coarse gravel & Cobbles	Caliche (Nitrate-bearing Gravel/Rock)	750-1600 <i>(85-181)</i>	60-100+
3	Dense, Fine Sands, very hard silts & clays (may be pre-loaded)	Basalt Till, Boulder Clay, Caliche, Weathered Laminated Rock	750-1600 <i>(85-181)</i>	45-60
4	Dense sands & gravel, hard silts & clays	Glacial Till, Weathered Shale's, Schist, Gneiss & Sandstone	600-750 <i>(68-85)</i>	35-50
5	Medium dense sand & gravel; very stiff to hard silts and clays	Glacial Till, Hardpan, Marls	500-600 <i>(58-68)</i>	24-40
6	Medium dense coarse sands & sandy gravels; stiff to very stiff clays	Saprolite's, Residual Soils	400-500 <i>(45-56)</i>	14-25
7	Loose to medium dense fine to coarse sands to stiff clays and silt	Dense Hydraulic Fill, Compacted Fill, Residual Soils	300-400 <i>(34-45)</i>	7-14
8	Loose, fine sands; alluvium; loess; medium & varied clays, fill	Flood Plain Soils, Lake Clays, Abode, Fill	100-200 <i>(11-25)</i>	4-8
9	Peat, organic silts, inundated silts, fly ash, very loose sands, very soft	Miscellaneous Fill, Swamp Marsh	Less than 100	0-5

Once the soil classification is known the appropriate auger can be selected.

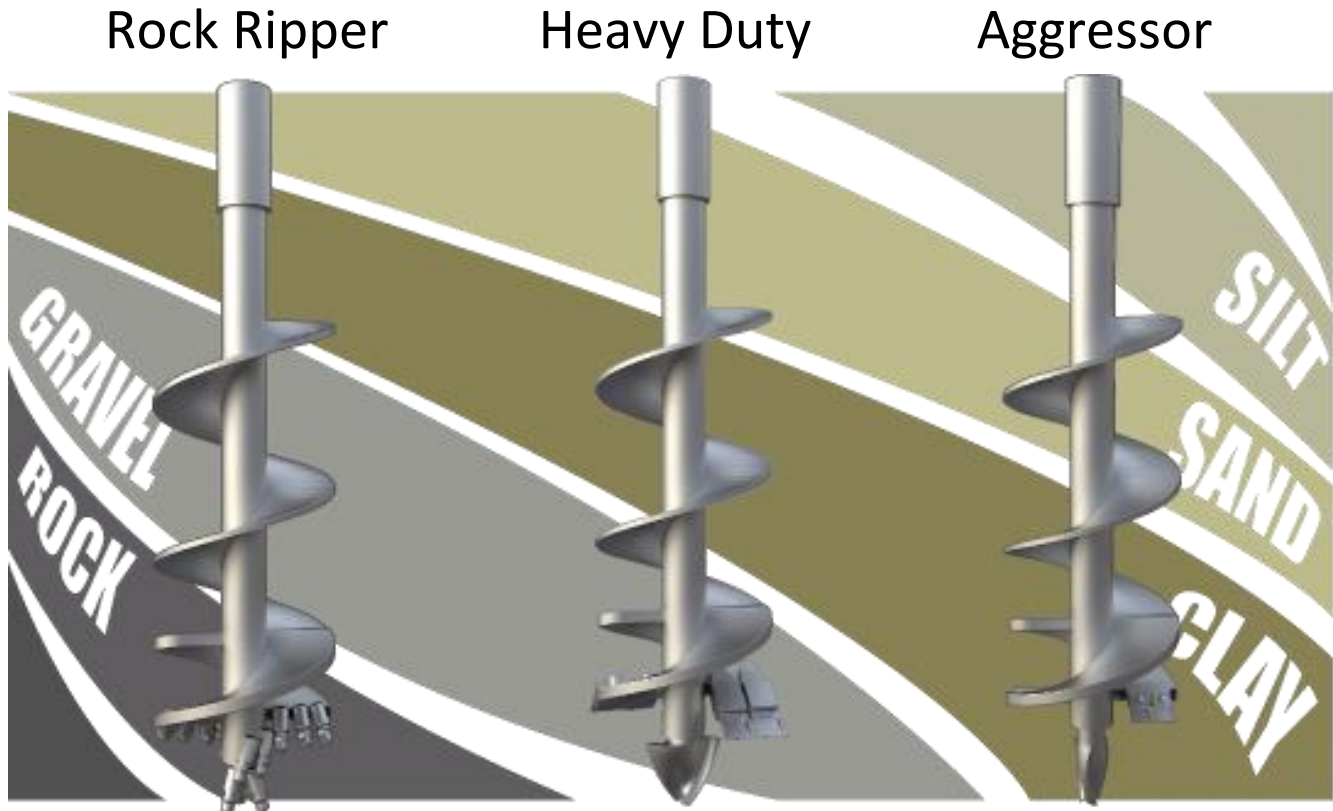

Aggressor Augers

Designed for drilling in loose soil and sand, Aggressor Augers come in 1.2m lengths, with an optional 1m extension.

These suit powerheads with up to a maximum rated output of 4500Nm. They use a 2" hexagon socket industry standard drive. Standard teeth are bolt on drop forged high carbon steel and carbide versions are available.

Heavy Duty Augers

Designed for drilling in dense gravel and soil, Heavy Duty Augers come in 1.2m lengths, with an optional 1m extension

These suit powerheads with up to a maximum rated output of 15,000Nm. They use a 2" hexagon or 65mm hexagon drive. Teeth are drop forged special steel or carbide tipped, retained with a rubber lock system.

Rock Ripper Augers

Designed for drilling solid rock, Rock Ripper Augers come in 1.2m lengths, with an optional 1m extension

These feature a unique computer generated tooth layout utilising self-sharpening carbide teeth which rotates in work. Whilst they do not perform well in hard clay soils, they will drill all materials up to hard concrete. Drilling performance in hard conditions depends on the application of sufficient down force. If additional down force is require a Rockmaster hammer system is available from Autoguide.

Autoguide have a wide range of different Augers available to dig holes ranging from 6" to 36" diameter in all soil classifications. These can be both rented and purchased.

POWERHEAD INSTALLATION

The safe operation of this equipment is the responsibility of the operator, who should be familiar with the lifting process, the power unit and all safety practices before starting operations.

The Autoguide Rope Wind Up bracket has been designed to enable powerheads for lorry mounted cranes to be permanently mounted on the crane whilst having minimal disruption to the cranes generic usage.

SAFETY: **Never place any part of your body where it could get trapped, crushed or injured. Careful operation and a common sense approach will ensure you achieve these objectives.**

IMPORTANT: **The Rope Wind Up unit is a welded construction and therefore cannot be dismantled for servicing. In the unlikely event that a problem arises, the unit must be returned to Autoguide Equipment Ltd for any repair or service work.**

Preparing the Powerhead

The powerhead and bracket comes attached directly to the crane so no installation or attaching is required each time the powerhead is to be used. Therefore only system checks are required.

1. Raise and lower the crane boom to make sure that there is no interference with the boom or swivel bracket.
2. Once complete, lower the auger unit to the ground while not in use.

Pre-operation check list

1. Keep bystanders away from all rotating attachments.
2. Ensure you are aware of the environment you are working in; be aware of overhead cabling and other utilities services.

POWERHEAD OPERATION

Operating the Rope Wind-Up Bracket

This method utilises the auger tube as a winch to wind the auger up to a latch. We provide an overwind valve to prevent rope breakage and an air controlled latch to release the auger for work.

The auger hangs from the centre of the boom when working, but stows at an angle to permit full crane articulation. The system usually uses 2m long augers as the crane cannot normally fold up in transport. Versions are available to achieve this where necessary.

Releasing the Powerhead

1. Position the crane boom parallel to the ground with enough clearance for the auger and Powerhead to be lowered.



- Put the powerhead in reverse using the hydraulic circuit to rotate and tighten the rope, taking the weight of the Powerhead and auger.

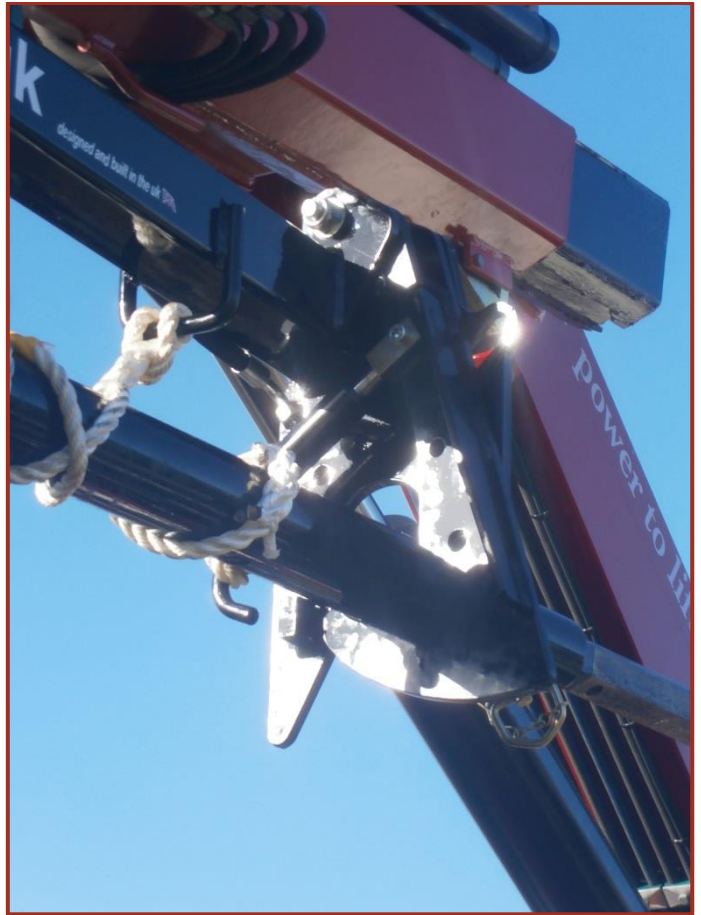

- Operate the hydraulic circuit to open the bottom latch using the inbuilt ram. Then put the powerhead into forward drive to gently lower itself through the opened latch.



4. Keep the forward drive applied to the powerhead until the unit hangs free and the rope detaches itself.



5. The powerhead is now ready for use.

Drilling Holes

1. Attach the Auger to the powerhead by sliding it over the hexagon bar output.



2. Insert the safety pin through the corresponding holes on both the auger and powerhead.
3. Carefully raise the powerhead on the crane boom into position with the tip of the auger resting on the ground at the desired hole position.
4. Operate the auxiliary circuit on the crane to start the powerhead turning.
5. Let the auger penetrate the surface. It may require some additional downwards force depending on the soil classification.
6. Gradually bore out the hole, removing the auger at regular intervals to remove the excess material.

General Principles of Operation

All powerheads are designed to stall at the rated operating pressures before anything breaks, however continuous operation of stalled motors will overheat the hydraulic system and cause expensive damage. Therefore operate as fast as required but avoid excessive motor stall.

When drilling it is better to remove the auger from the hole when it is half full of soil and remove the excess. If loose material comes beyond the top of the auger it may act as an anchor and prevent the auger from being raised. In such cases engage reverse to get it out.

Always replace worn teeth before damage occurs to the tooth holders. Regular hard face welding will extend the auger life. Rock Ripper augers will drill very hard material but the rate of penetration depends on the down force available. The Rockmaster hammer system available from Autoguide permits high penetration rates even with lorry mounted cranes.

In hard material careful addition of water to the powder material in the hole will allow the auger to work at increased rates.

Storing the Powerhead

1. Set the boom parallel to the ground with the tip of the auger just touching the surface and the rope bracket facing the crane.



2. Attach the rope to the hook.



3. Put the powerhead into reverse and the unit will slowly start to wind itself up.

Note: The principle is to keep the rope tight but allow gravity to fold the auger into the latch. Gentle adjustment of the crane boom may be required.



4. The dome on the powerhead should enable to rope to wind up smoothly but be vigilant in case of snagging.



5. As the powerhead winds itself; up it will pass through the sprung latch. It will not keep winding once past this point due to an override switch when it reaches the extreme.



6. Reverse the powerhead until the weight of the Powerhead is resting on the latch and not tensioning the rope.

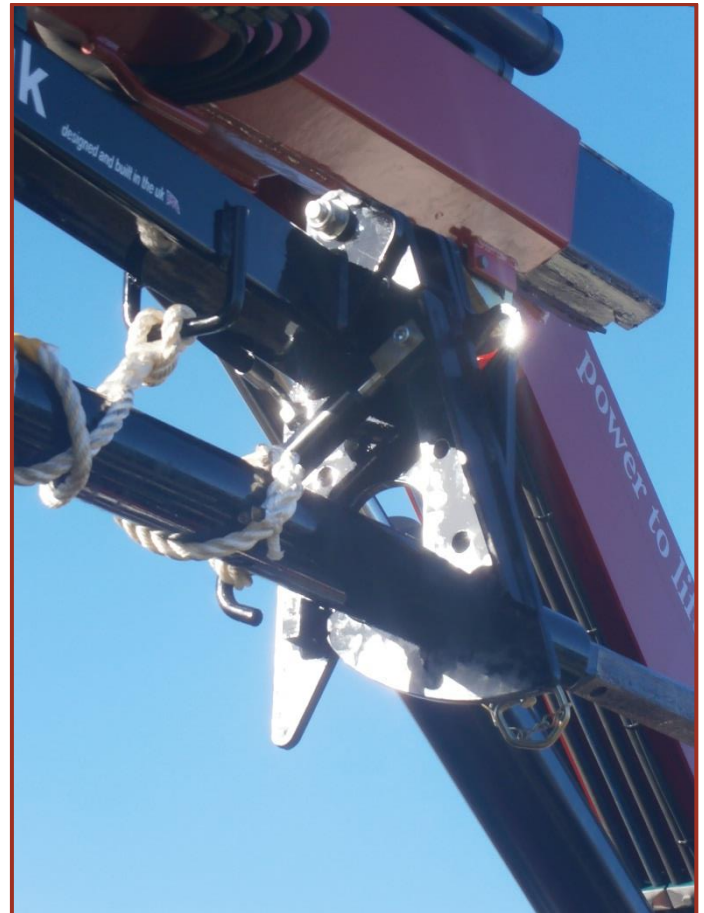

7. The powerhead is now stored securely.

MAINTENANCE SCHEDULE

Daily

- Check the unit is properly and securely attached to the crane unit.
- Check that all mounting pins are properly retained.
- Check the condition and security of any auger and anchor driver attachment.
- Check hydraulic hoses and fitting for leaks and damage.
- Check that the rope is not frayed, cut or damaged.

Weekly

- Check that all nuts and bolts are secure.
- Lubricate all grease nipples.



- Check relief valve on the motor, ensuring it is not leaking.

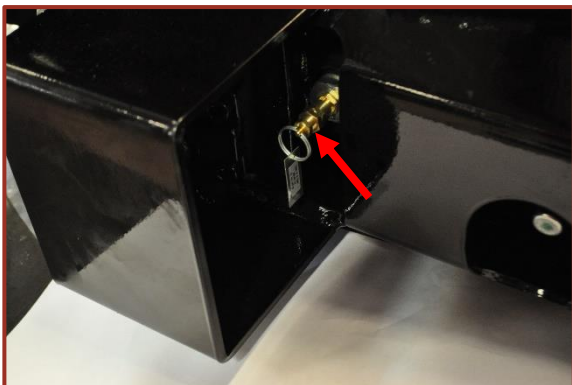

Monthly

- Check condition of auger teeth and replace if required.
- Visually check for damage to arm, powerhead body, auger and attachments.

Annually

- Check the powerhead body for signs of fatigue and weld failure.
- Check the mounting top plate for signs of fatigue and weld failure.
- Check the arm and catcher plate's signs of fatigue and weld failure.
- Check all pins and bosses for damage and signs of wear.
- Pressure check the hydraulic system.
- Check each fitting and valve for leaks, damage and wear.
- Examine each hose for leaks, cuts, abrasion and wear.
- Check output seals on gearbox for wear and leaks.
- Drain gear oil and checked for signs of gear wear, replaced to correct level.

TROUBLESHOOTING

Symptom	Possible Cause	Action
Jerky	Cold Oil	Allow time to warm up
	Air in Pipes	Check oil Level
	Non Compatible Quick Couplers	Use Matched pairs
	Non Compatible Quick Couplers	Replace
	Hoses too small for flow	Replace
Slow	Wrong Model Powerhead	Select appropriate model
	Pump Failing	Carry Out flow and Pressure Check
	Oil Filter Blocked	Carry Out flow and Pressure Check
	Dirt Contamination	Service Exchange Motor
Poor Torque	Low Speed Lock Engaged	Put Selector in Auto
	Low Hydraulic Pressure	Carry Out Flow and Pressure Check
	Excessive Oil Temperature	Check Pump, Check Hose Sizes, Use Correct Powerhead
Oil leaks	Relief Valve Blows	Use smaller Auger or Larger Powerhead
	Loose Fittings	Tighten Up Fittings
	Leaky Connections	Reseal or check Configuration
Leak from Relief Valve	Pressure Too High	Use compatible head and fittings
	Drain Link is Kinked	Check 2 bar max back Pressure. Replace Relief Valve.
	Non Return Valve Seizes	Remove unit and check ball is free moving. Ball can become wedged & sticky, due to high pressure (over 20 bar) or extended storage. Replace valve & relief valve

END OF LIFE

When the machine reaches the end of its useable lifetime it is important that the independent elements of the machine are reused, recycled or disposed of suitably.

Component	What to do?
Metals	All metals should be recycled with an appropriate scrap metal merchant, preferable sorted into metal type.
Electronics	All electrical components should be recycled at an appropriate facility according to the WEEE Directive and Regulations 2013
Oils	Oil waste is classed as Hazardous and therefore must be stored separately and according to legal regulations (that differ dependent on country). It must be disposed of by a suitable Waste Oil collection company.
Hydraulic Hoses	Hydraulic hoses should be drained of oil, metal ends removed and then recycled with a suitable specialist recycling company. Metal ends can be sent to metal recycling centers.
Plastics	All plastics should be sorted into recyclable and non recyclable and then either sent to suitable recycling facilities or landfill.

SPARE PARTS

Wind-Up Bracket

48414		Rope Wind-up 40,000 PXV	
No.	Code	Description	QTY
1	02977	WASHER M8 (FORM C)	4
2	46667	1M 2" HEX EXTENTION ASSY BT	1
3	46662	BT AUGER 12" RR 1.8M 2" ASSY	1
4	03231	ROPE STROP M016 X 2.2M	1
5	49255	WIND-UP HYDRAULICS	1
6	49256	ROPE WIND-UP ASSY 1	1
7	02454	BOLT HEX M8 X 60	2
8	02496	NUT NYLOC M8	2

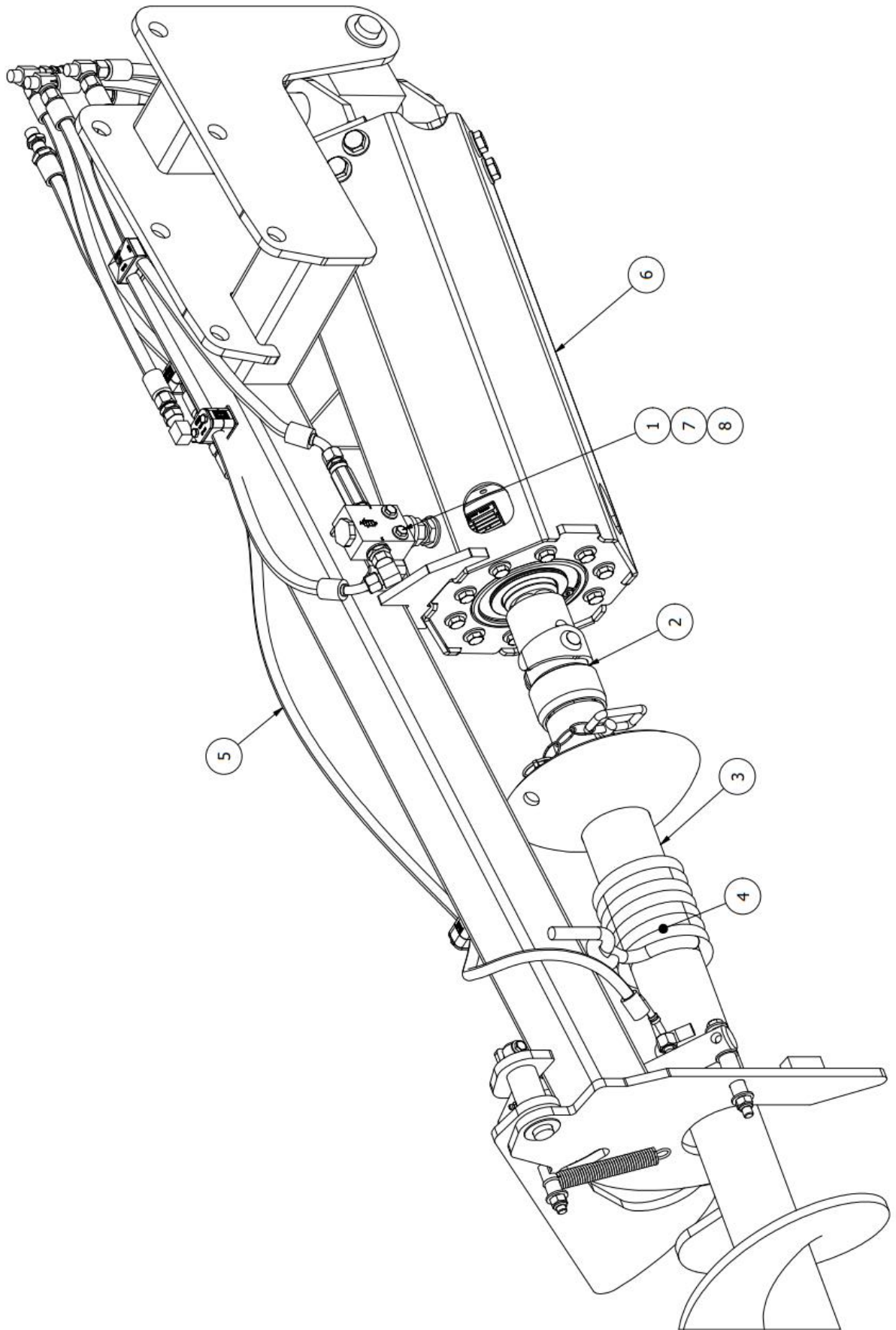

Rope Wind Up Assembly 1

49256		Rope Wind-up Assy 1	
No.	Code	Description	QTY
1	48413	ARM WA	1
2	48412	LATCH WA	1
3	51202	PIVOT PIN WA	1
4	02838	SPRING	1
5	47251	40,000 PXV POWERHEAD	1
6	03248	IGUS BUSH 2528 - 25	2
7	23620	SWIVEL UNIVERSAL BLOCK	1
8	10624	RAM M20 BRAKE BR20	1
9	27622	VALVE STOP SCREW	1
10	02105	WASHER M12 (FORM C)	5
11	02774	NUT NYLOC M12	2
12	05078	BOLT HEX M12 X 130	2
13	02137	NIPPLE GREASE M6X1	2
14	02977	WASHER M8 (FORM C)	2
15	02496	NUT NYLOC M8	1
16	03431	PIN LYNCH M009 X 045	1
17	48927	SWIVEL PIN WA	1
18	01895	BOLT HEX M8 X 50	1
19	06772	CLAMP STAUFF M014 SINGLE	1
20	11078	CLAMP STAUFF M016 SINGLE	2
21	01819	CLAMP STAUFF M016 DOUBLE	1
22	03868	WASHER M20 (FORM C)	1
23	06922	NUT LOCK M20	1

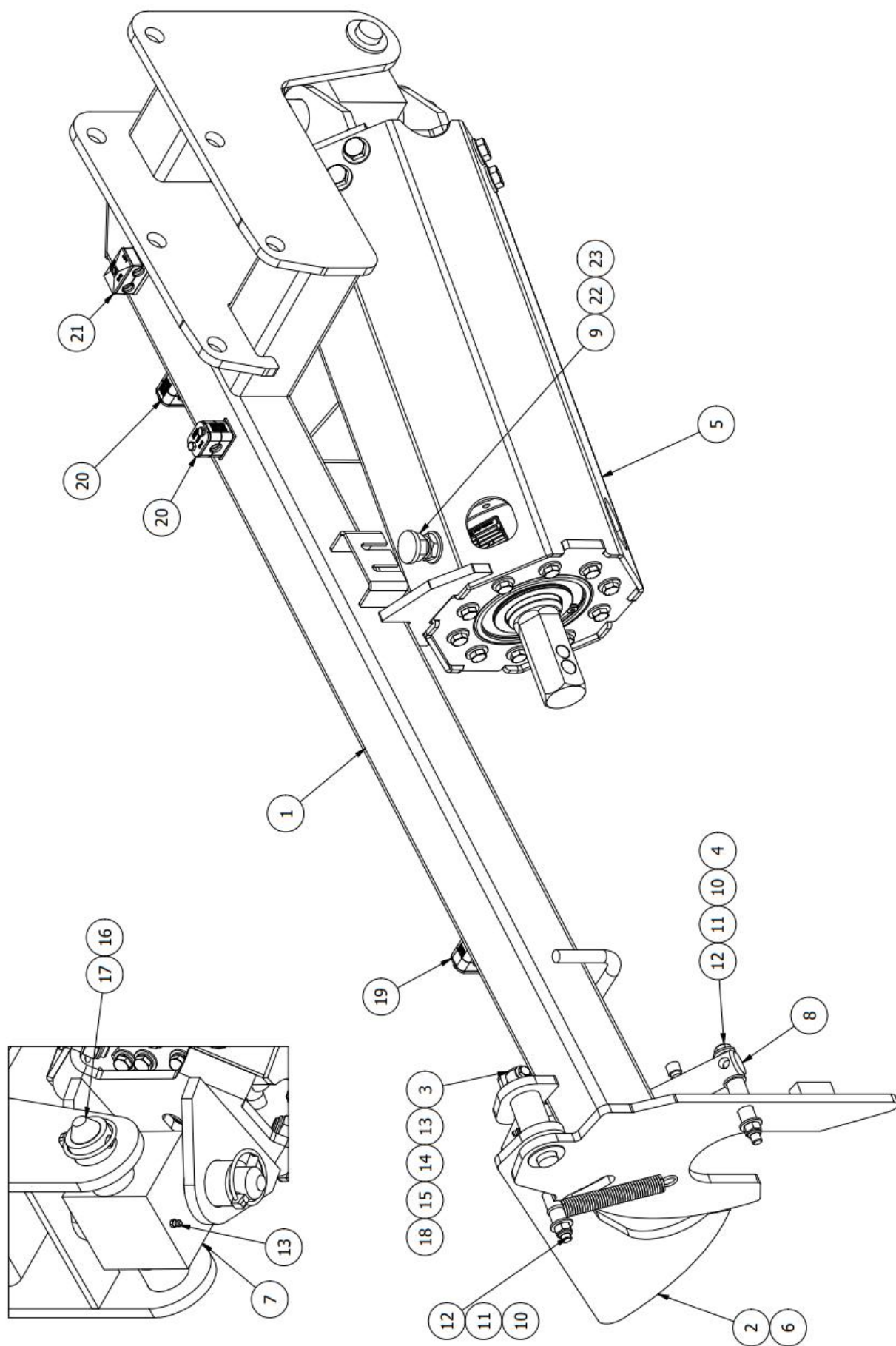

Rope Wind Up Hydraulics

49255		Wind-Up Hydraulics	
No.	Code	Description	QTY
1	10692	VALVE OVERWIND 008	1
2	02182	SEAL BONDED 008	2
3	01096	3/8"-1/2" MM ADAPTOR	2
4	01628	3/8" CHECK VALVE VUR IN LINE	2
5	01812	SEAL BONDED 006	4
6	01095	3/8" MM ADAPTOR	3
7	49258	HOSE 1	1
8	49260	HOSE 2	1
9	49261	HOSE 3	1
10	49262	HOSE 4	1
11	49263	HOSE 5	1
12	49264	HOSE 6	3
13	01134	TEE 006 MMM BSP	3
14	07580	3/8" MM RESTRICTOR ADAPTOR 0.5MM	1
15	02188	TEE 006 FMM BSP	1
16	01120	ELBOW 006 SH MF BSP	1
17	04881	ELBOW 006 SH FF BSP	1

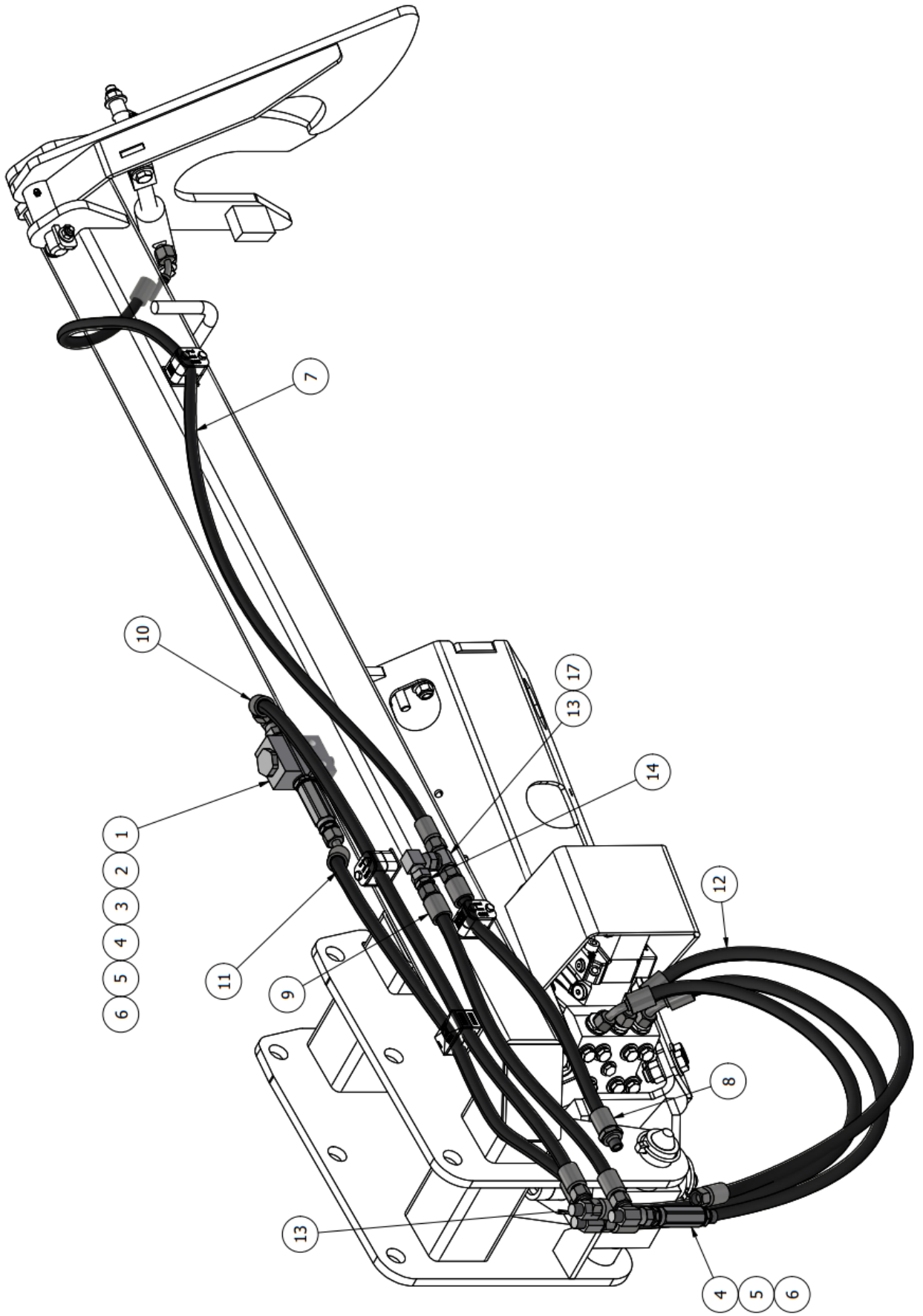

Powerhead

Code		Description	
47251		40,000 PXV Powerhead	
No.	Code	Description	QTY
1	47246	BODY 40,000 WA	1
2	47250	TOP PLATE WA	1
3	23368	TOP PIN WA	1
4	01578	MOTOR	1
5	02137	NIPPLE GREASE M6X1	1
6	47400	50,000 PXV PORT BLOCK	1
7	06653	GEARBOX	1
8	02104	WASHER M16 (FORM C)	16
9	02105	WASHER M12 (FORM C)	20
10	10167	BOLT HEX M12 X 50	10
11	03941	NUT NYLOC M16	8
12	06000	BOLT SET M16 X 45	8
13	02774	NUT NYLOC M12	10
14	09425	PIN LYNCH M009 X 052	1
15	02182	SEAL BONDED 008	6
16	01812	SEAL BONDED 006	1
17	01923	1/2 BANJO BOLT	1
18	01096	MM ADAPTOR	1
19	02702	WASHER M10 (FORM C)	8
20	02525	WASHER SPRING M10	8
21	02986	BOLT HEX M10 X 70	8
22	09156	ADAPTOR 008/011 BSP ORFS MM	3
23	47259	HOSE 1	1
24	01813	SEAL BONDED 004	2
25	02132	PLUG 004	2
26	01677	PLUG 006	1

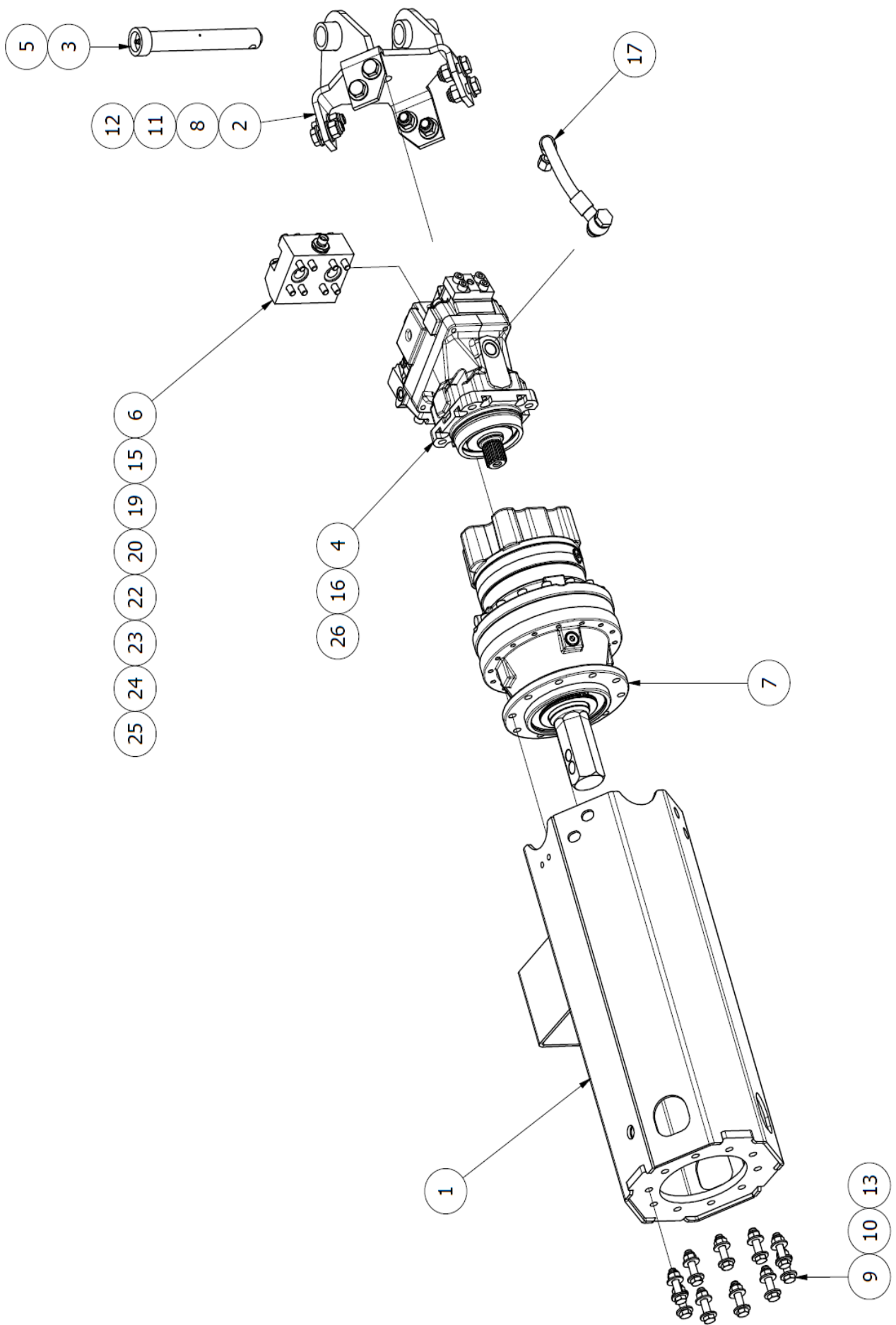



Autoguide Equipment
Stockley Road
Heddington
Nr. Calne
Wiltshire SN11 0PS
England
Tel: +44 (0) 1380 850885
Website: www.autoguide.co.uk

